

4

3

2

1

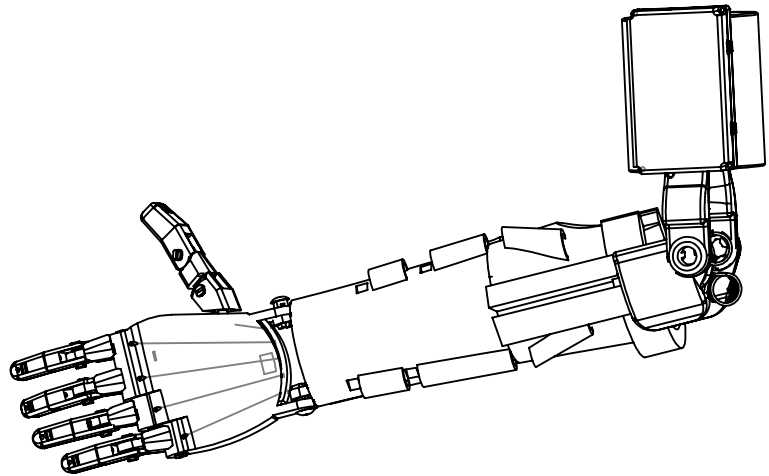
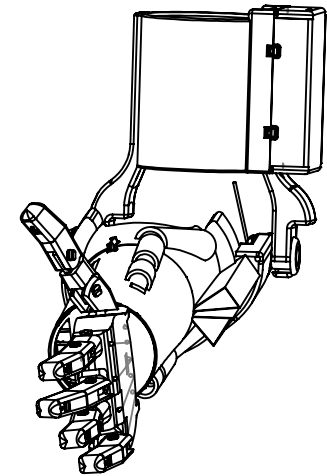
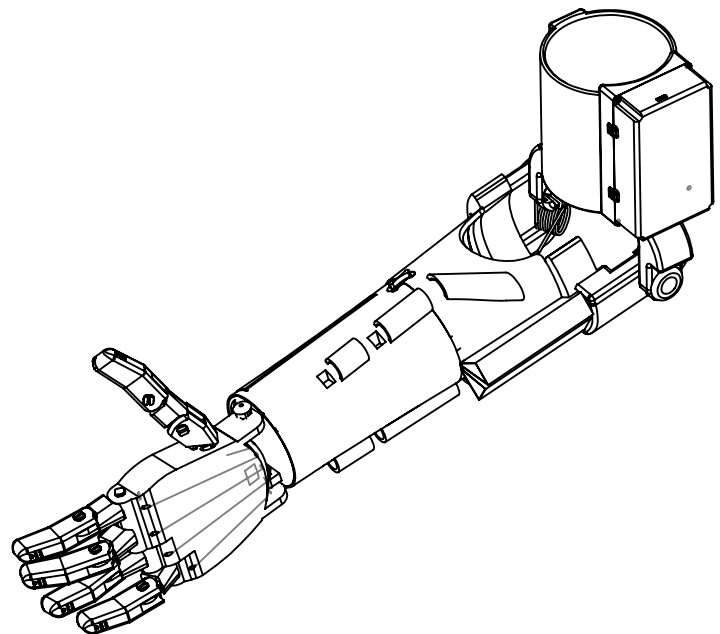
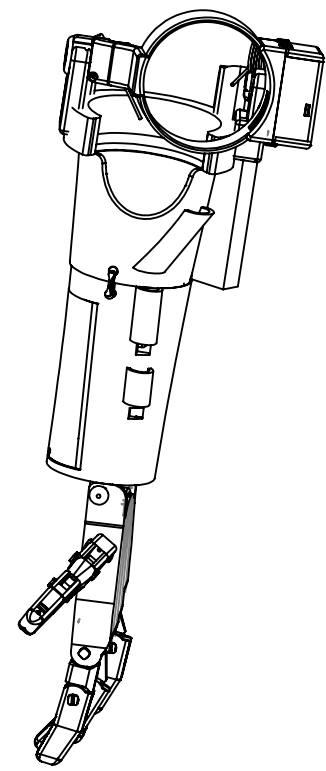

B

B

A

A

**PROPRIETARY AND CONFIDENTIAL**  
 THE INFORMATION CONTAINED IN THIS DRAWING IS THE SOLE PROPERTY OF <INSERT COMPANY NAME HERE>. ANY REPRODUCTION IN PART OR AS A WHOLE WITHOUT THE WRITTEN PERMISSION OF <INSERT COMPANY NAME HERE> IS PROHIBITED.

		UNLESS OTHERWISE SPECIFIED:	NAME	DATE	TITLE: <h1>Active Prosthetic Assembly</h1>		
		DIMENSIONS ARE IN INCHES	DRAWN				
		TOLERANCES: FRACTIONAL ± ANGULAR: MACH ± BEND ± TWO PLACE DECIMAL ± THREE PLACE DECIMAL ±	CHECKED				
		INTERPRET GEOMETRIC TOLERANCING PER:	ENG APPR.				
		MATERIAL	MFG APPR.		SIZE	DWG. NO.	REV
NEXT ASSY	USED ON	FINISH	COMMENTS:		<h2>Total_armBassembly_04142019</h2>		
APPLICATION		DO NOT SCALE DRAWING			SCALE: 1:10	WEIGHT:	SHEET 1 OF 3

4

3

2

1

4

3

2

1

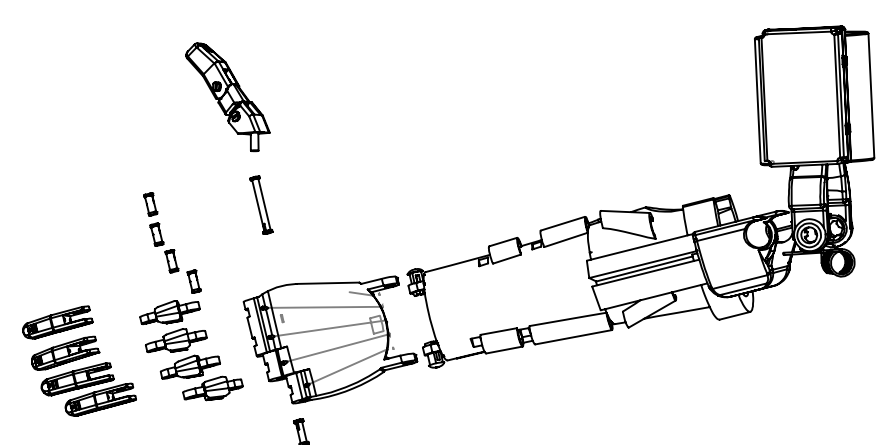
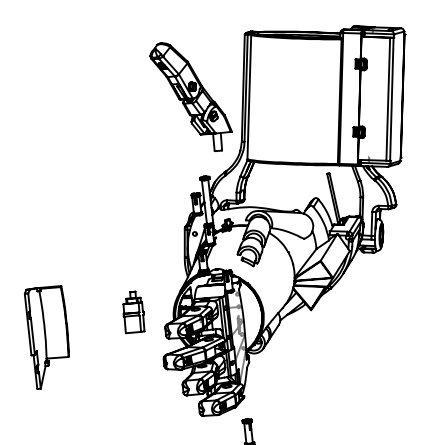
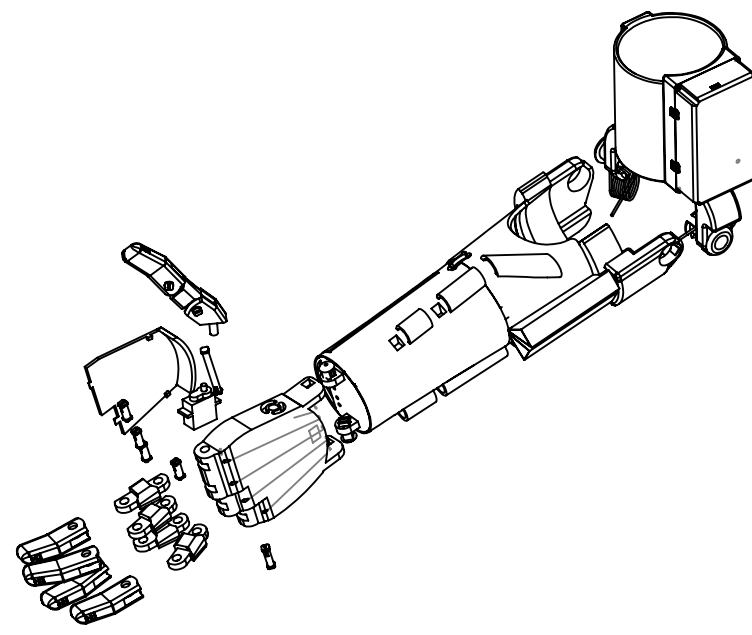
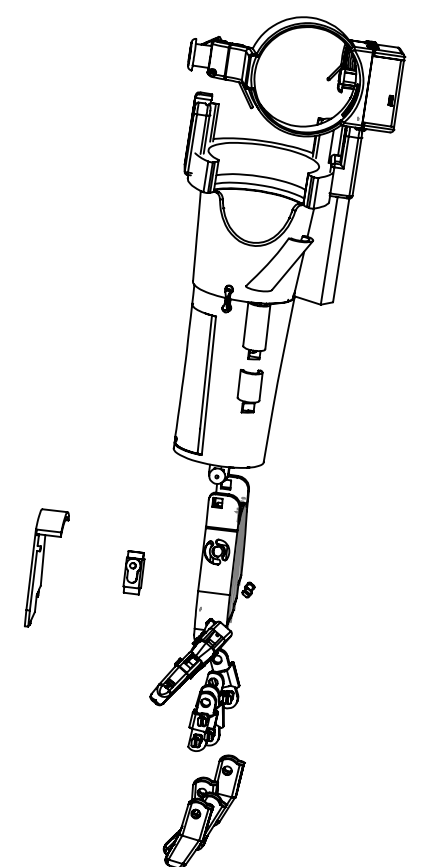

B

B

A

A

**PROPRIETARY AND CONFIDENTIAL**  
 THE INFORMATION CONTAINED IN THIS DRAWING IS THE SOLE PROPERTY OF <INSERT COMPANY NAME HERE>. ANY REPRODUCTION IN PART OR AS A WHOLE WITHOUT THE WRITTEN PERMISSION OF <INSERT COMPANY NAME HERE> IS PROHIBITED.

		UNLESS OTHERWISE SPECIFIED:	NAME	DATE	TITLE: <b>Active Prosthetic Exploded View</b> SIZE DWG. NO. REV <b>Total_armBassembly_04142019</b>
		DIMENSIONS ARE IN INCHES	DRAWN		
		TOLERANCES: FRACTIONAL ± ANGULAR: MACH ± BEND ± TWO PLACE DECIMAL ± THREE PLACE DECIMAL ±	CHECKED		
		INTERPRET GEOMETRIC TOLERANCING PER:	ENG APPR.		
		MATERIAL	MFG APPR.		
NEXT ASSY	USED ON	FINISH	Q.A.		
APPLICATION		DO NOT SCALE DRAWING	COMMENTS:		

4

3

2

1

SCALE: 1:10 WEIGHT: SHEET 2 OF 3

4

3

2

1

B

B

ITEM NO.	PART NUMBER	Exploded View/QTY.
1	forearm assembly1	1
2	motor	1
3	Base_Digit 1 040142019	1
4	Proximal_Digit 1-5 04062019	5
5	Distal_Digit 1 04142019	1
6	Distal_Digit 2 04142019	1
7	Distal_Digit 3 04142019	1
8	Distal_Digit 4 04142019	1
9	Distal_Digit 5 04142019	1
10	Digit Hinge Pin Rotating Base 04114019	1
11	Digit Hinge Pin 04114019	5
12	bpalm	1
13	040719electronicscas e	1
14	20190318VM	3
15	20190326Cuff	1
16	20190326springpin	2
17	spring	2
18	palm	1
19	top2pin1.23.19	1
20	regularpin1.23.19	1

A

A

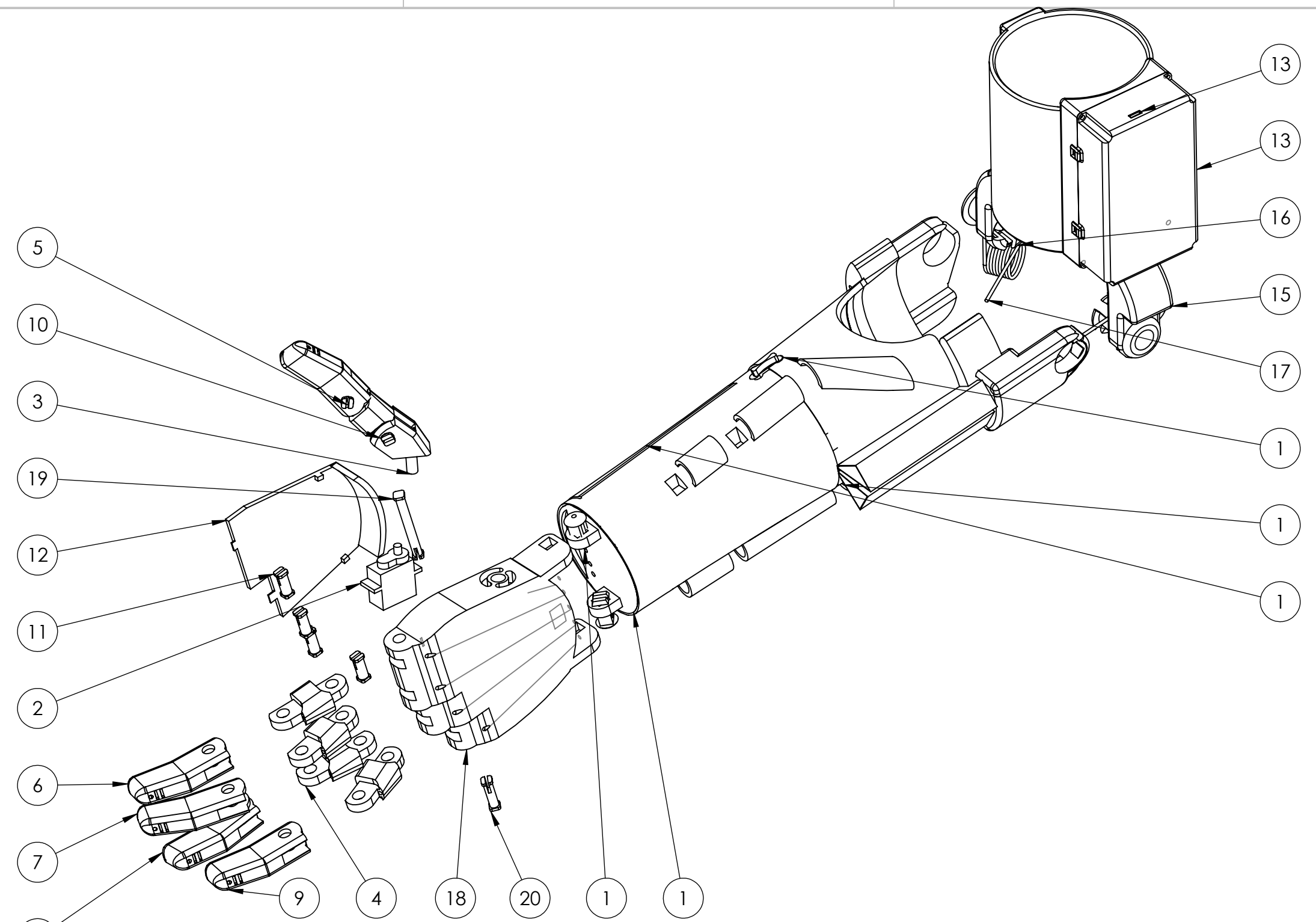

**PROPRIETARY AND CONFIDENTIAL**  
 THE INFORMATION CONTAINED IN THIS DRAWING IS THE SOLE PROPERTY OF <INSERT COMPANY NAME HERE>. ANY REPRODUCTION IN PART OR AS A WHOLE WITHOUT THE WRITTEN PERMISSION OF <INSERT COMPANY NAME HERE> IS PROHIBITED.

UNLESS OTHERWISE SPECIFIED:		NAME	DATE	
DIMENSIONS ARE IN INCHES		DRAWN		
TOLERANCES:		CHECKED		
FRACTIONAL ±		ENG APPR.		
ANGULAR: MACH ± BEND ±		MFG APPR.		
TWO PLACE DECIMAL ±		Q.A.		
THREE PLACE DECIMAL ±		COMMENTS:		
INTERPRET GEOMETRIC TOLERANCING PER:	MATERIAL	<b>Active Prosthetic Exploded View</b> Total_armBassembly_04142019		
FINISH				
APPLICATION	DO NOT SCALE DRAWING			
NEXT ASSY	USED ON	SIZE	DWG. NO.	REV
		SCALE: 1:10 WEIGHT:		SHEET 3 OF 3

4

3

2

1

2

1

B

B

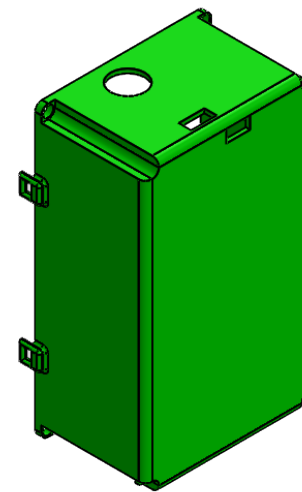
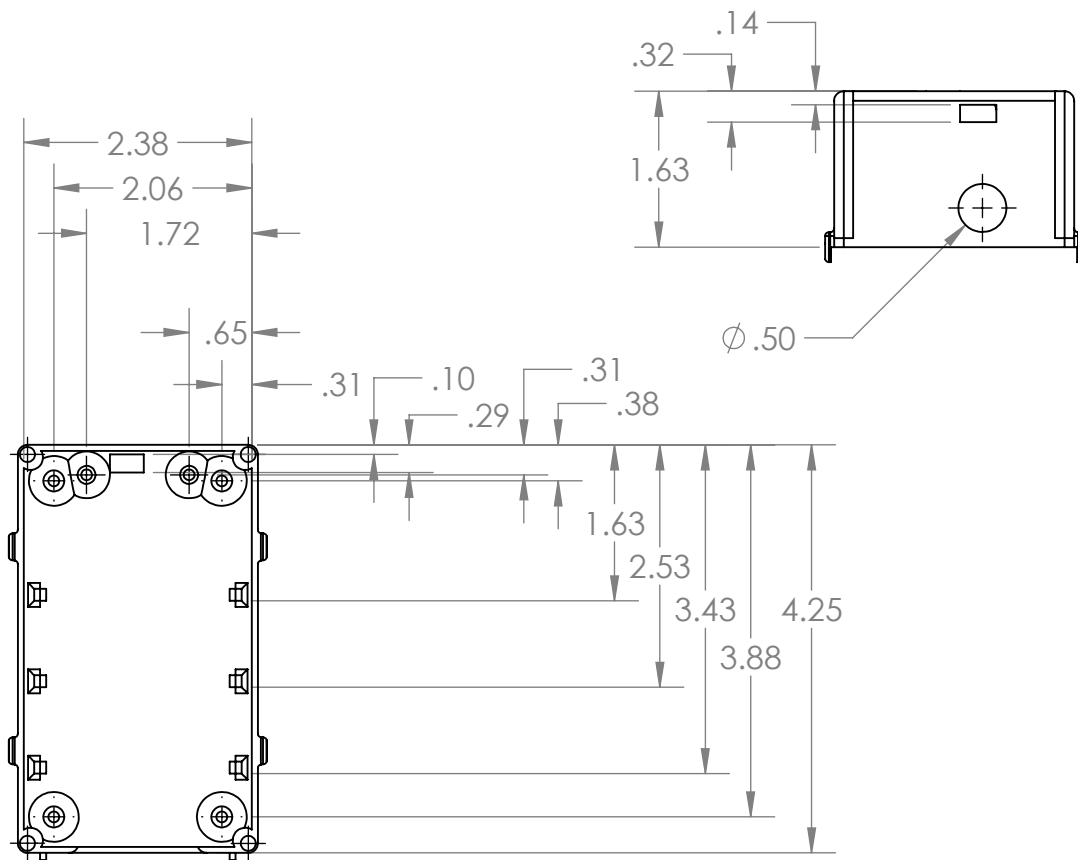

A

A

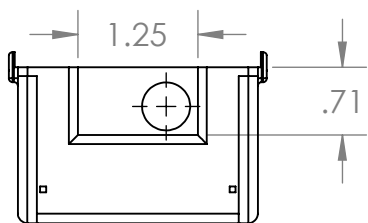

UNLESS OTHERWISE SPECIFIED:		TITLE:	
DIMENSIONS ARE IN INCHES TOLERANCES: 0.03125 FRACTIONAL $\pm 1/32$ TWO PLACE DECIMAL $\pm 0.03$ THREE PLACE DECIMAL $\pm 0.031$		190428eCase	
SIZE		REV	
<b>A</b>		3.3	
SCALE: 1:2		SHEET 1 OF 1	

2

1

2

1

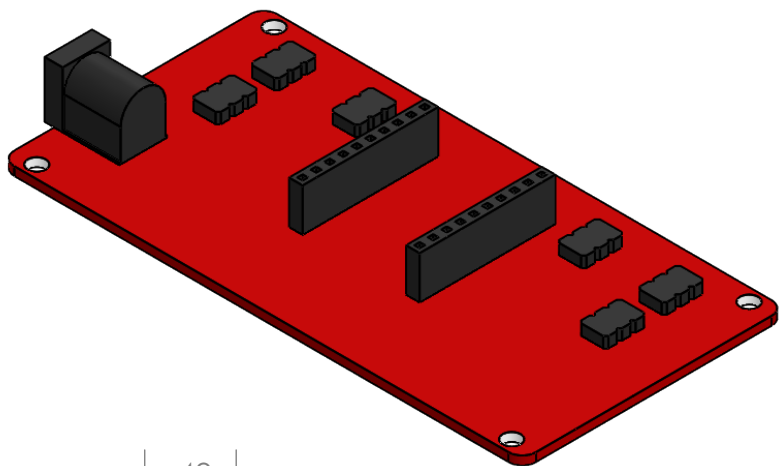

B

B

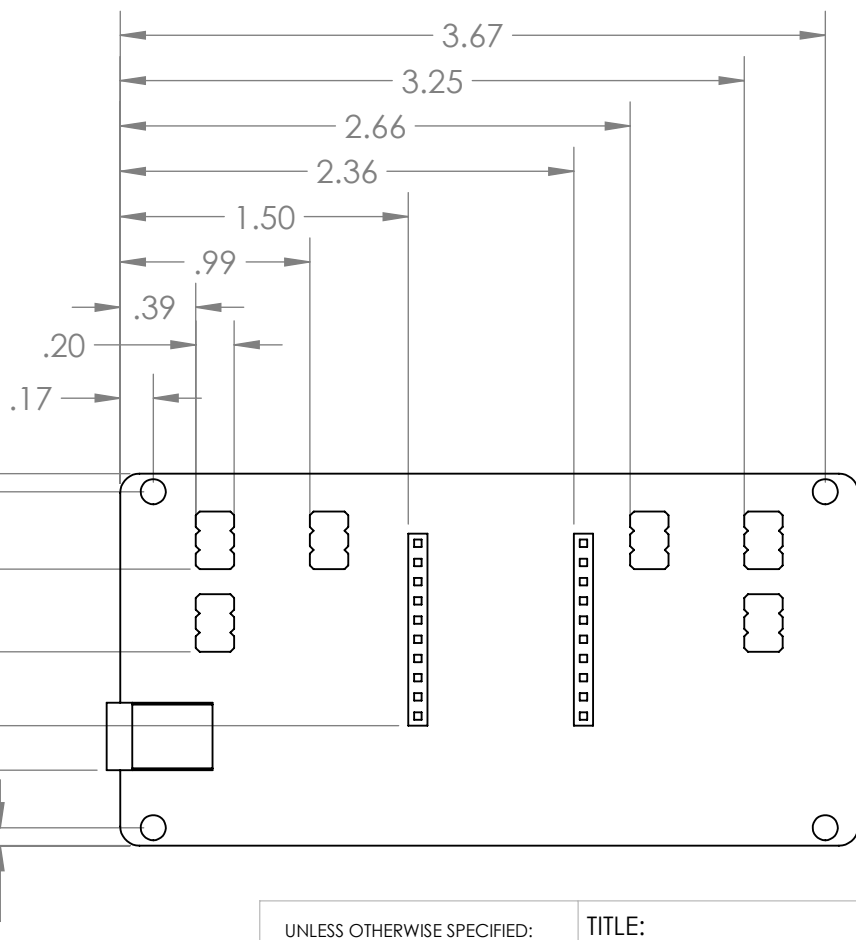
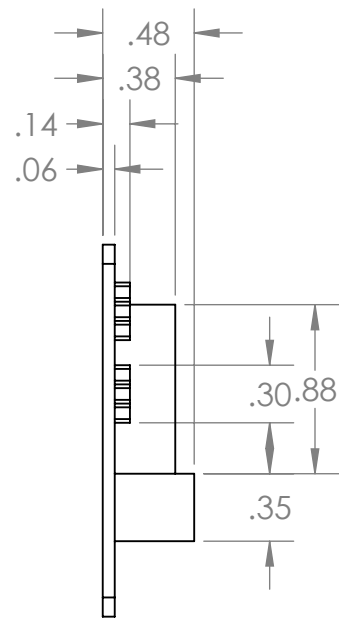

A

A

UNLESS OTHERWISE SPECIFIED: DIMENSIONS ARE IN INCHES TOLERANCES: 0.03125 FRACTIONAL ± 1/32 TWO PLACE DECIMAL ±0.03 THREE PLACE DECIMAL ±0.031		TITLE:  190503 SparkFun RedBot Mainboard	
SIZE <b>A</b>		REV <b>3.3</b>	
SCALE: 1:1		SHEET 1 OF 1	

2

1

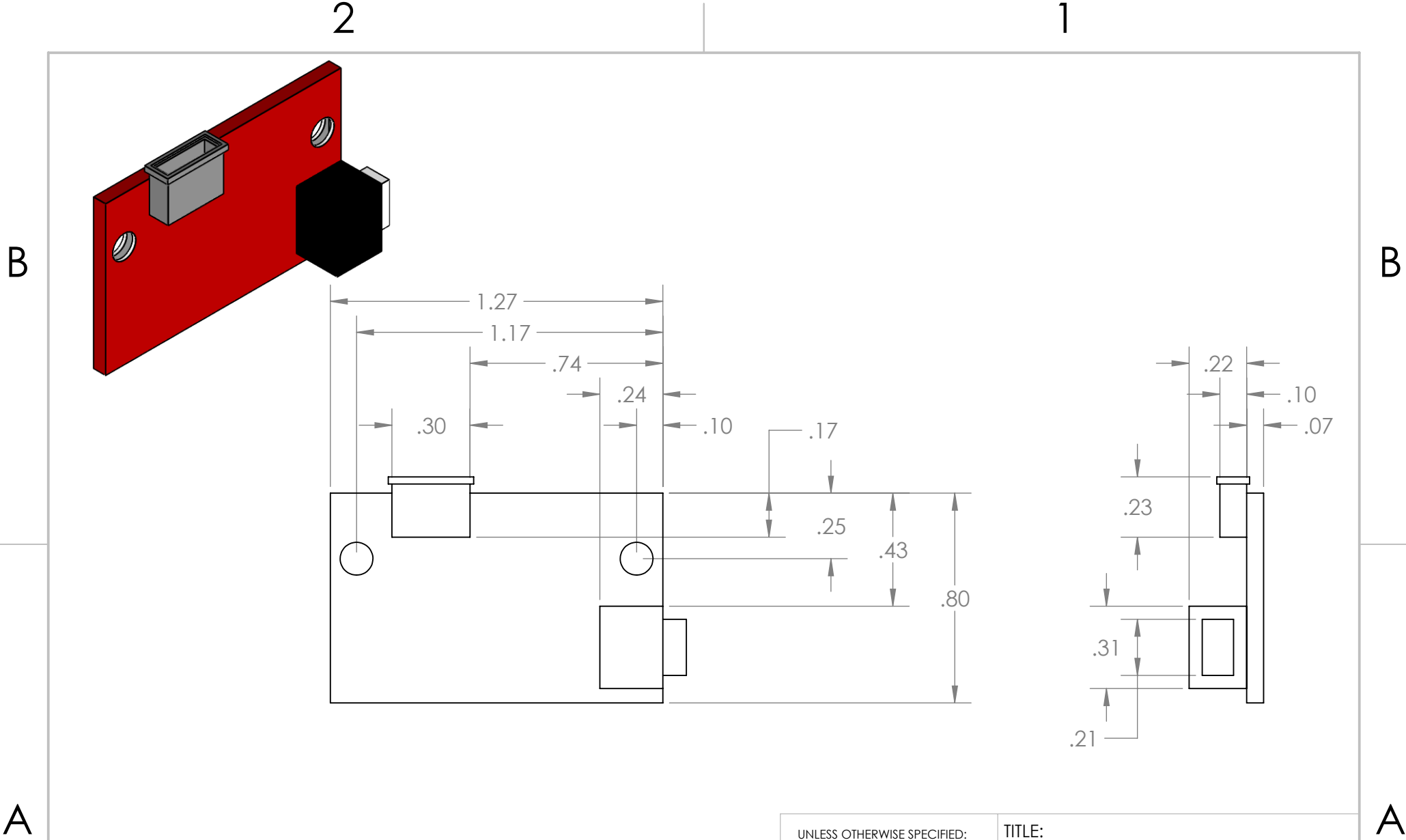

UNLESS OTHERWISE SPECIFIED:		TITLE:	
DIMENSIONS ARE IN INCHES TOLERANCES: 0.03125 FRACTIONAL $\pm 1/32$ TWO PLACE DECIMAL $\pm 0.03$ THREE PLACE DECIMAL $\pm 0.031$		190503BatteryBooster	
SIZE <b>A</b>		REV <b>3.3</b>	
SCALE: 2:1		SHEET 1 OF 1	

2

1

B

B

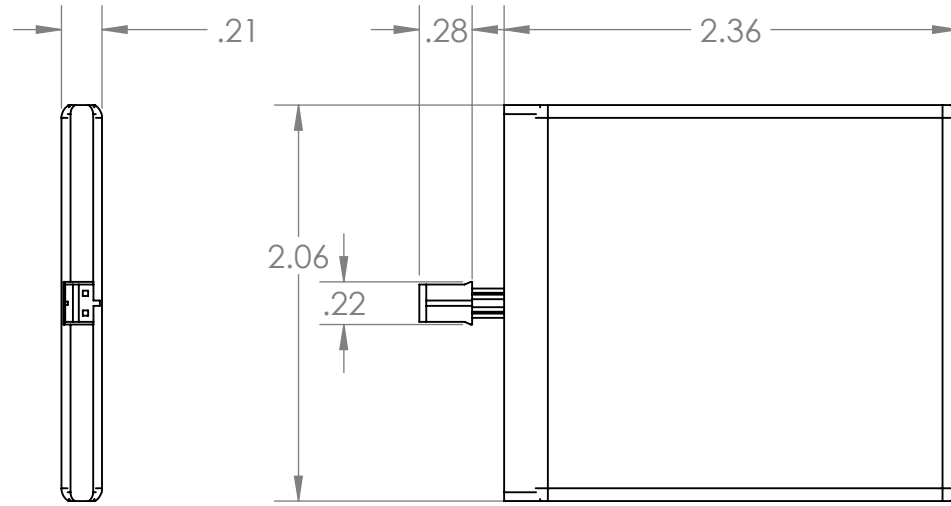
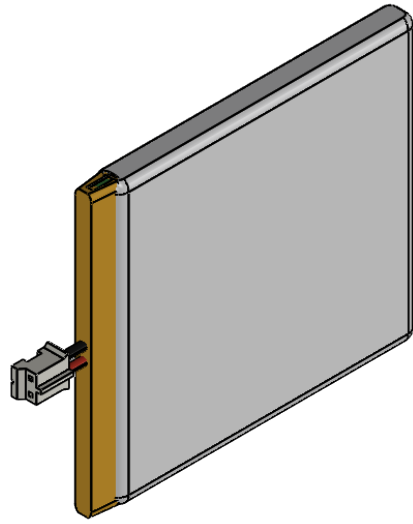

A

A

UNLESS OTHERWISE SPECIFIED:	TITLE:	
DIMENSIONS ARE IN INCHES TOLERANCES: 0.03125 FRACTIONAL ± 1/32 TWO PLACE DECIMAL ±0.03 THREE PLACE DECIMAL ±0.031	190503LiPo	
SIZE	REV	
<b>A</b>	3.3	
SCALE: 1:1		SHEET 1 OF 1

2

1

2

1

B

B

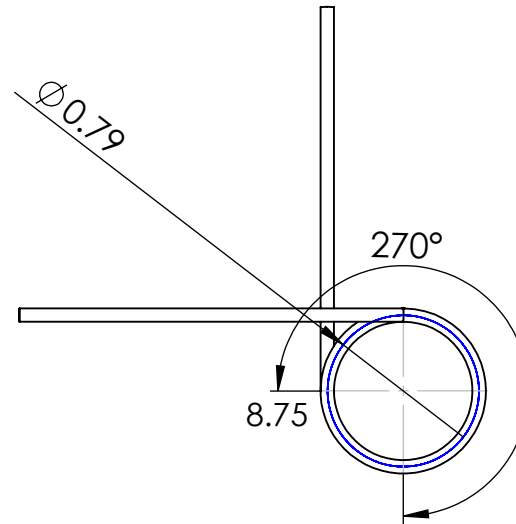
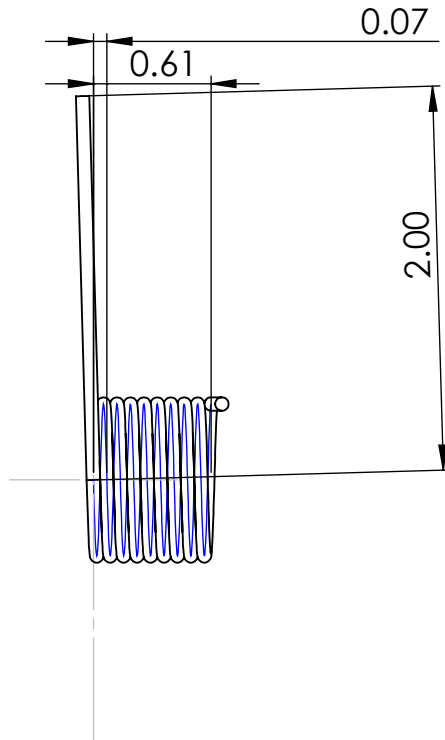
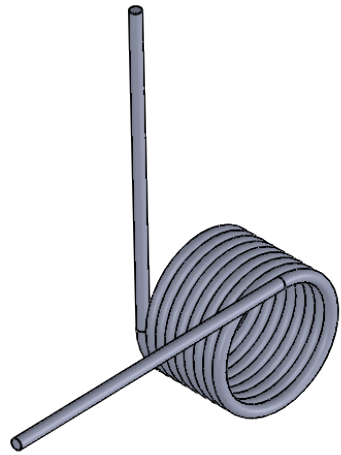

A

A

UNLESS OTHERWISE SPECIFIED:

DIMENSIONS ARE IN INCHES  
 TOLERANCES: 0.03125  
 FRACTIONAL  $\pm 1/32$   
 TWO PLACE DECIMAL  $\pm 0.03$   
 THREE PLACE DECIMAL  $\pm 0.031$

TITLE:

190503spring

SIZE

**A**

REV

**3.3**

SCALE: 1:1

SHEET 1 OF 1

2

1



2

1

B

B

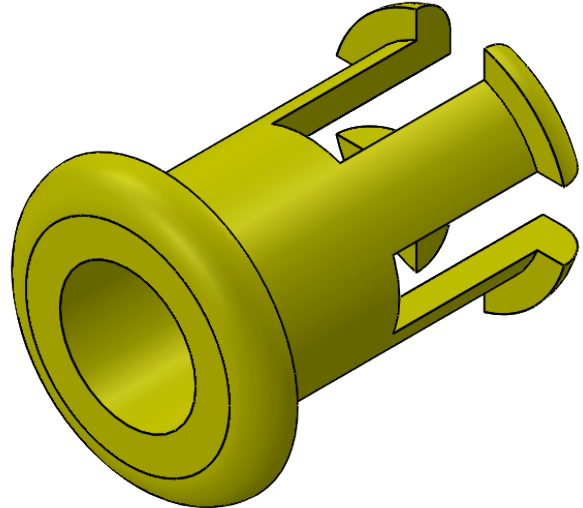

A

A

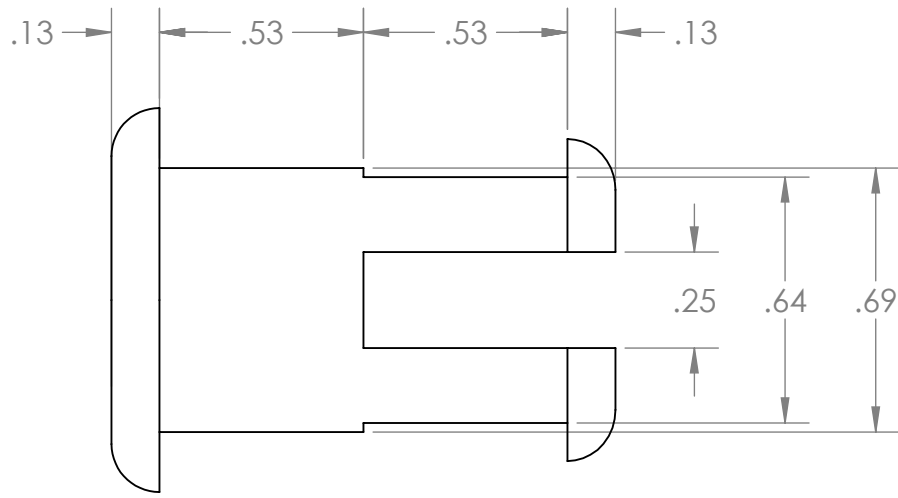
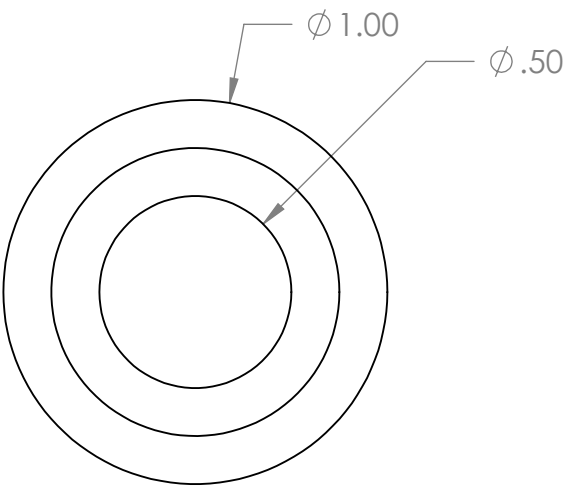

UNLESS OTHERWISE SPECIFIED: DIMENSIONS ARE IN INCHES TOLERANCES: 0.03125 FRACTIONAL $\pm 1/32$ TWO PLACE DECIMAL $\pm 0.03$ THREE PLACE DECIMAL $\pm 0.031$		TITLE: <b>190503springpin</b>	
SIZE <b>A</b>		REV <b>3.3</b>	
SCALE: 2:1		SHEET 1 OF 1	

2

1

2

1

B

B

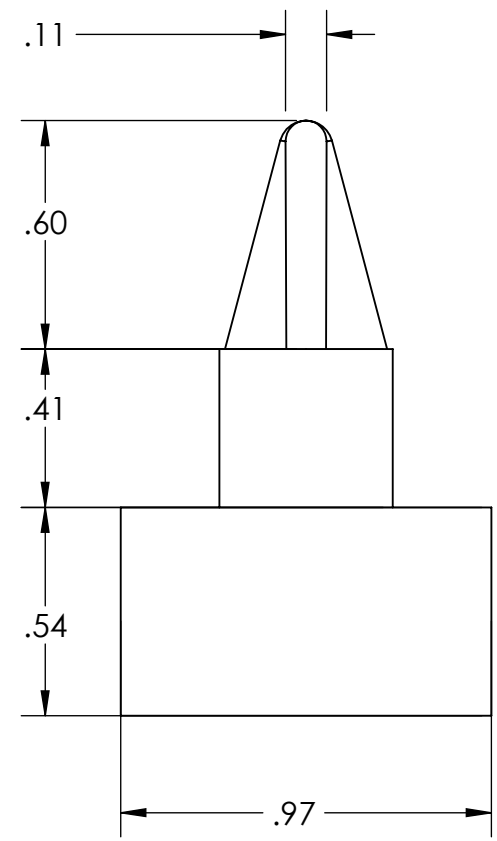
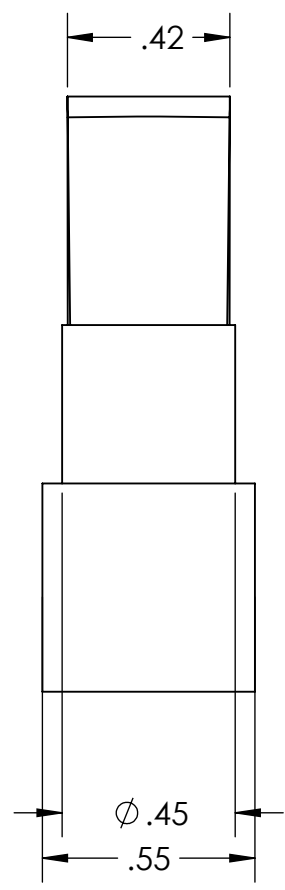
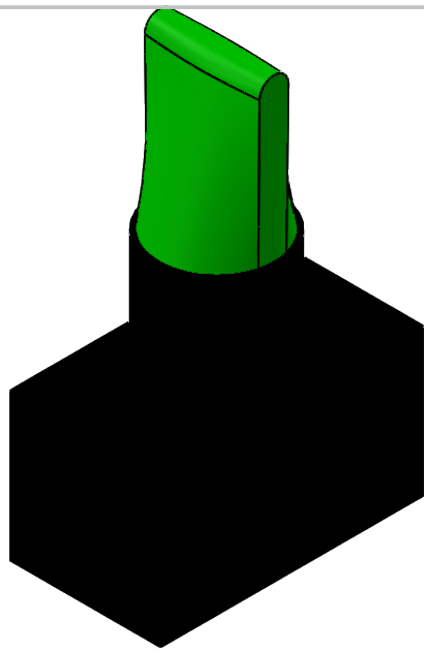

A

A

UNLESS OTHERWISE SPECIFIED: DIMENSIONS ARE IN INCHES TOLERANCES: 0.03125 FRACTIONAL ± 1/32 TWO PLACE DECIMAL ±0.03 THREE PLACE DECIMAL ±0.031	TITLE: <b>190503Switch</b>	
	SIZE <b>A</b>	REV <b>3.3</b>
SCALE: 2:1		SHEET 1 OF 1

2

1

2

1

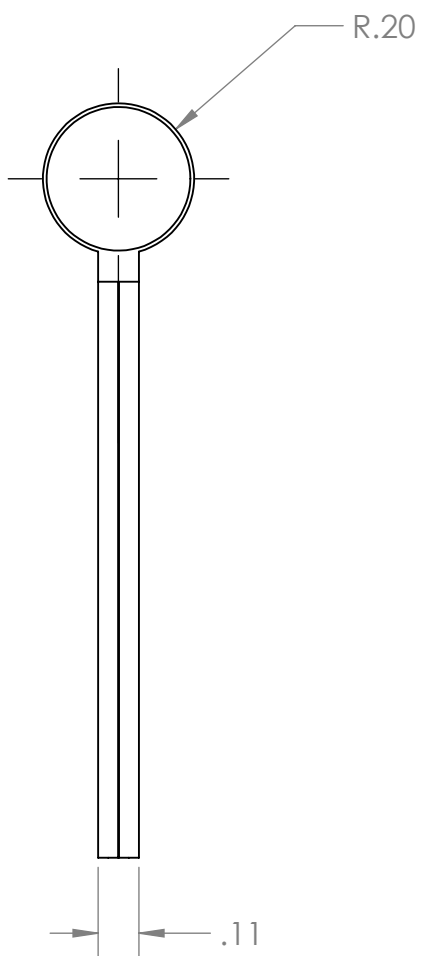
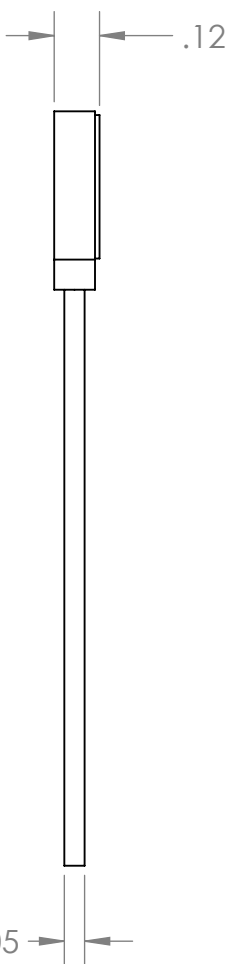
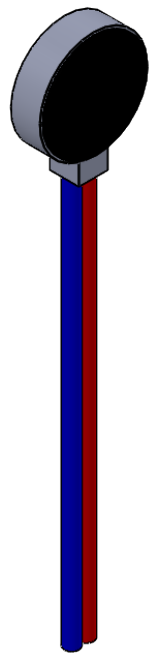

B

B

A

A

UNLESS OTHERWISE SPECIFIED: DIMENSIONS ARE IN INCHES TOLERANCES: 0.03125 FRACTIONAL $\pm 1/32$ TWO PLACE DECIMAL $\pm 0.03$ THREE PLACE DECIMAL $\pm 0.031$	TITLE: <b>190503VM</b>	
	SIZE <b>A</b>	REV <b>3.3</b>
SCALE: 2:1		SHEET 1 OF 1

2

1

2

1

B

B

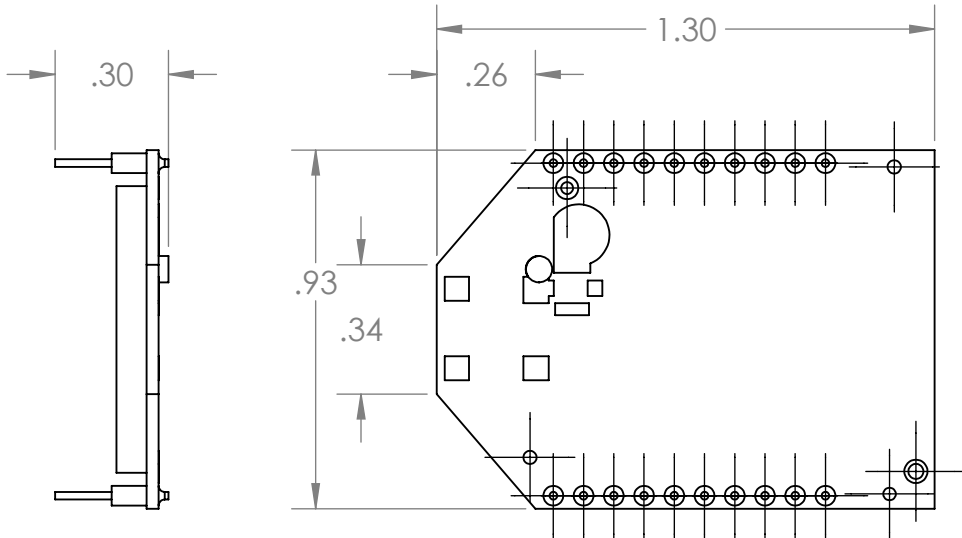
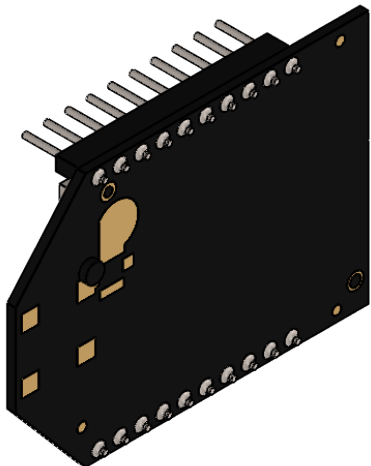

A

A

UNLESS OTHERWISE SPECIFIED:		TITLE:	
DIMENSIONS ARE IN INCHES TOLERANCES: 0.03125 FRACTIONAL ± 1/32 TWO PLACE DECIMAL ±0.03 THREE PLACE DECIMAL ±0.031		<b>190503XBeeProS1</b>	
SIZE		REV	
<b>A</b>		<b>3.3</b>	
SCALE: 2:1		SHEET 1 OF 1	

2

1

4

3

2

1

B

B

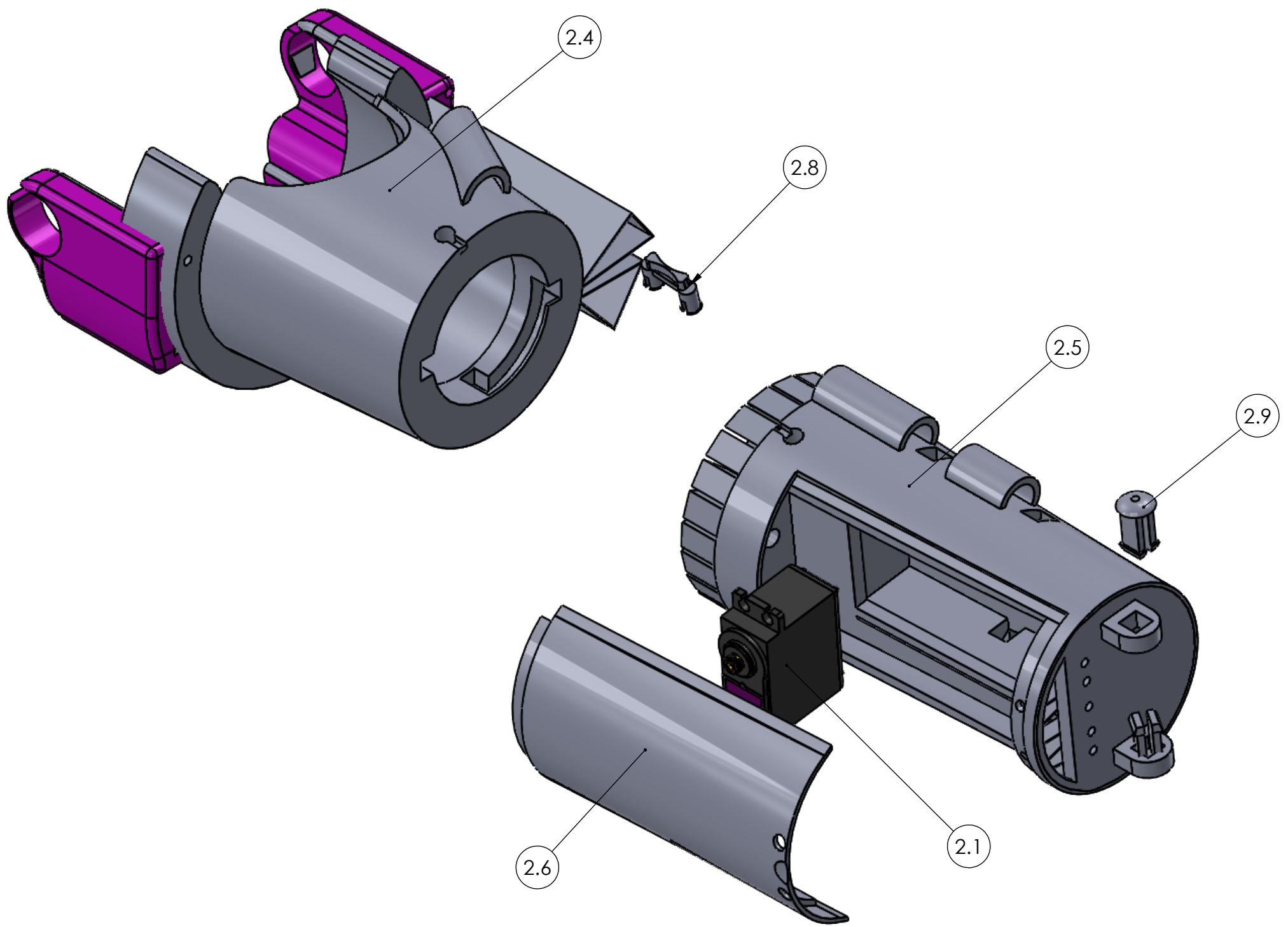

ITEM NO.	PART NUMBER	QTY.
2.5	front of arm2	1
2.1	Standard Servo	1
2.8	key attachment	1
2.6	front lid	1
2.9	Front to palm	2
2.7	lid to front	2
2.4	back arm with attachments3	1

A

A

4

3

2

1

**PROPRIETARY AND CONFIDENTIAL**  
 THE INFORMATION CONTAINED IN THIS DRAWING IS THE SOLE PROPERTY OF <INSERT COMPANY NAME HERE>. ANY REPRODUCTION IN PART OR AS A WHOLE WITHOUT THE WRITTEN PERMISSION OF <INSERT COMPANY NAME HERE> IS PROHIBITED.

TITLE:  
**2 FOREARM ASSEMBLY**

SIZE <b>B</b>	DWG. NO.	REV
SCALE: 1:5	WEIGHT:	SHEET 1 OF 7

4

3

2

1

B

B

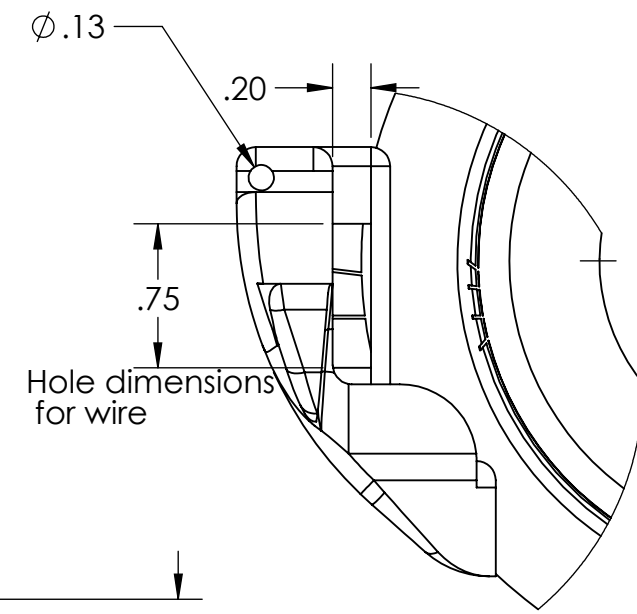
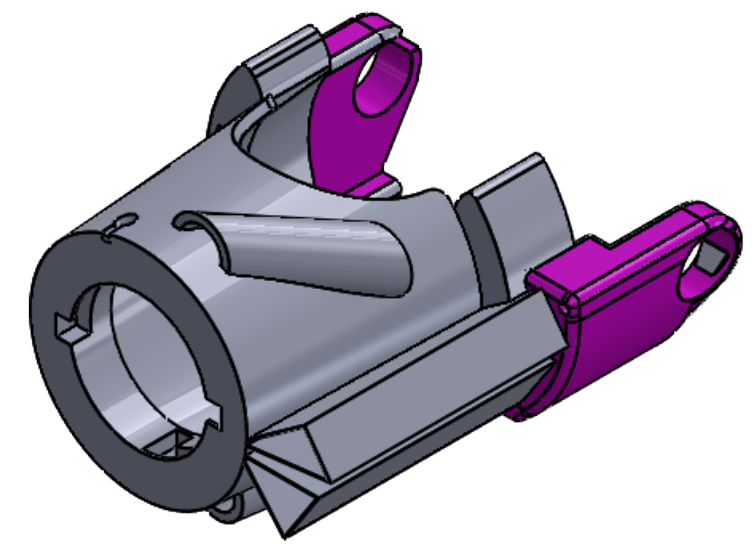
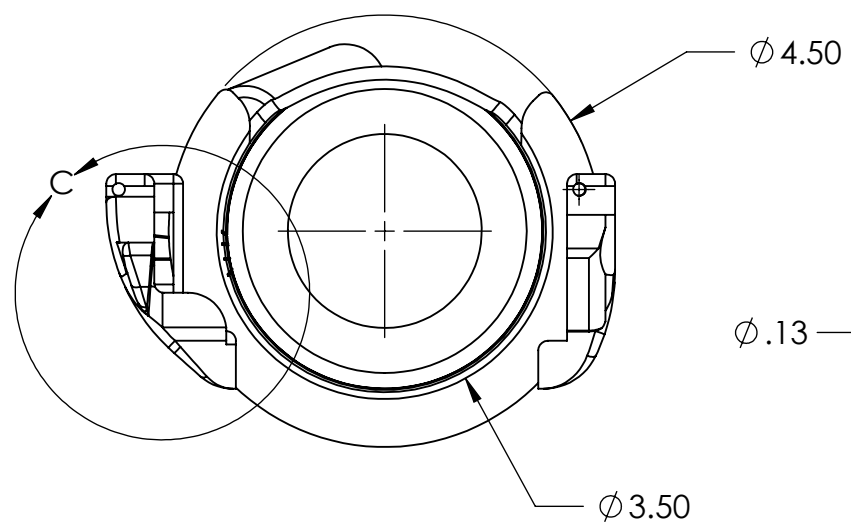
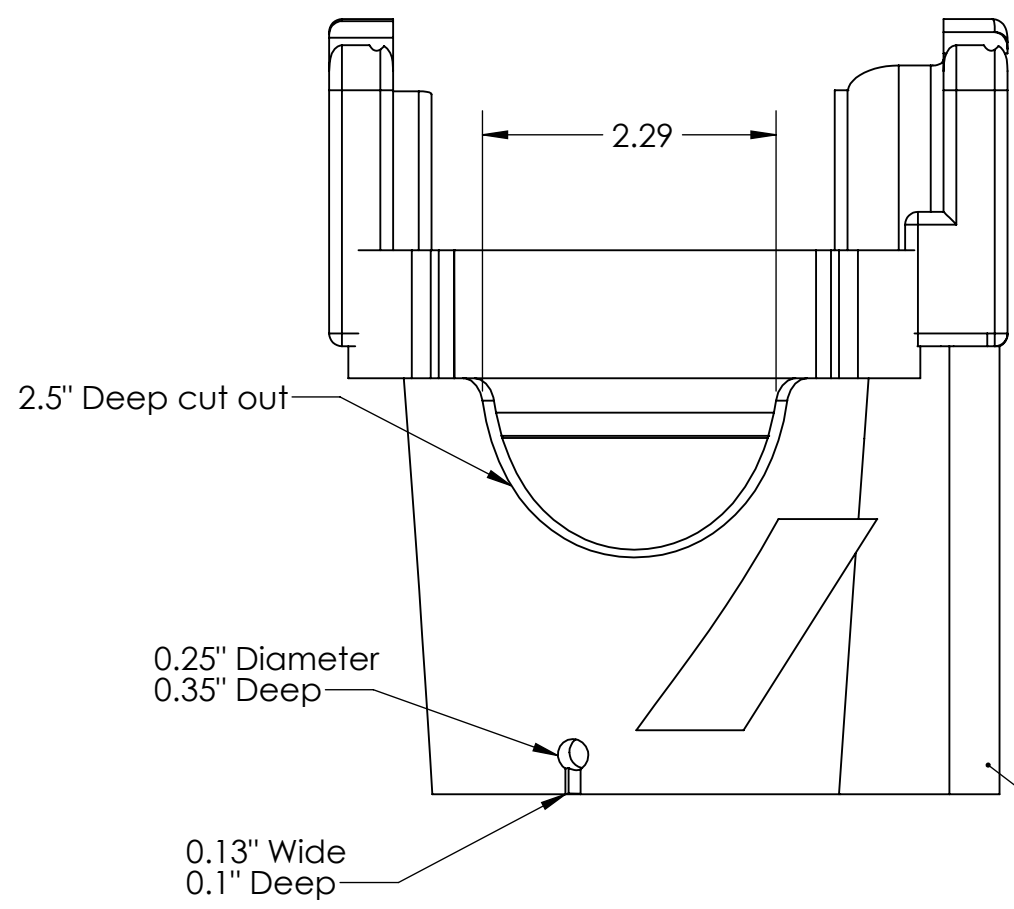

DETAIL C  
SCALE 1 : 1

Own Supports:  
Triangles 0.017" thick

A

A

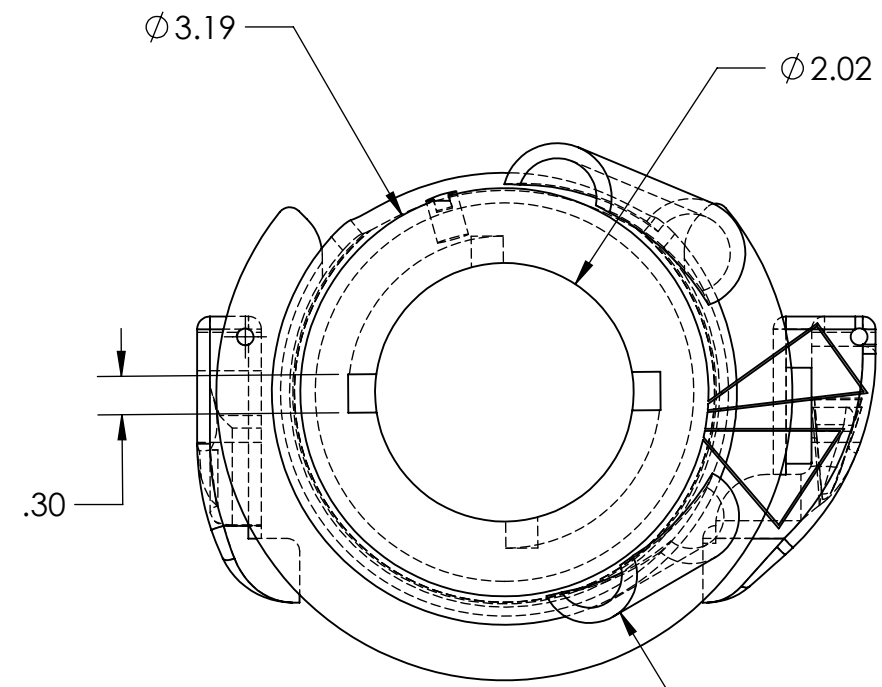

Wire Tubing:  
Arc at least 0.35" tall  
and 0.5" wide

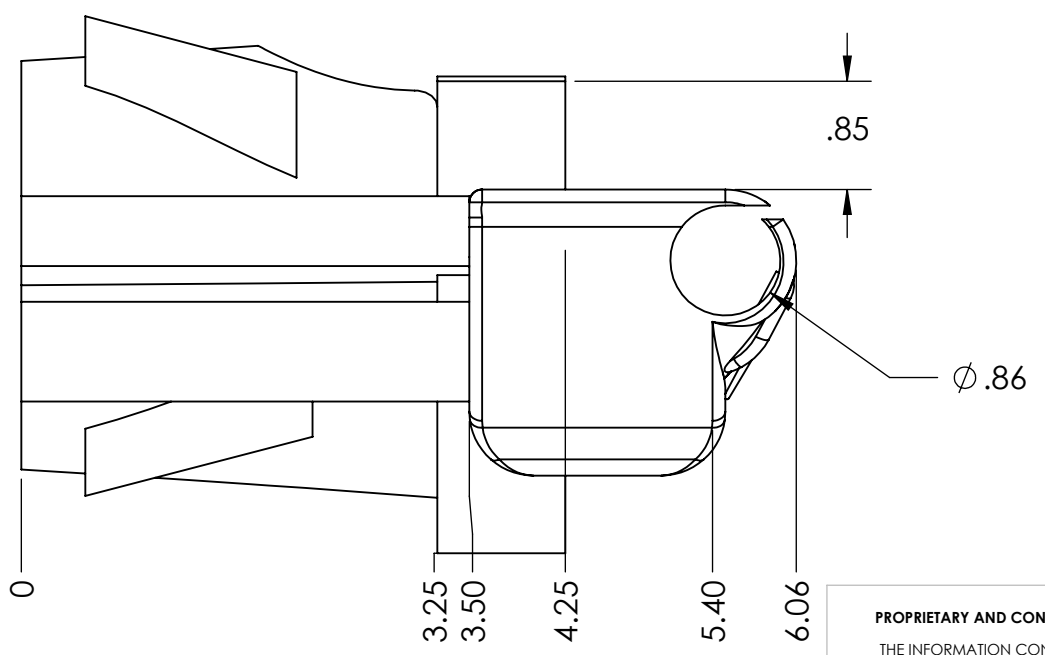

**PROPRIETARY AND CONFIDENTIAL**

THE INFORMATION CONTAINED IN THIS DRAWING IS THE SOLE PROPERTY OF <INSERT COMPANY NAME HERE>. ANY REPRODUCTION IN PART OR AS A WHOLE WITHOUT THE WRITTEN PERMISSION OF <INSERT COMPANY NAME HERE> IS PROHIBITED.

MATERIAL		PLA Filament	
TITLE:			
2.4 Back Half of Forearm			
SIZE	DWG. NO.	REV	
<b>B</b>			
SCALE: 1:2	WEIGHT:	SHEET 2 OF 7	

4

3

2

1

4

3

2

1

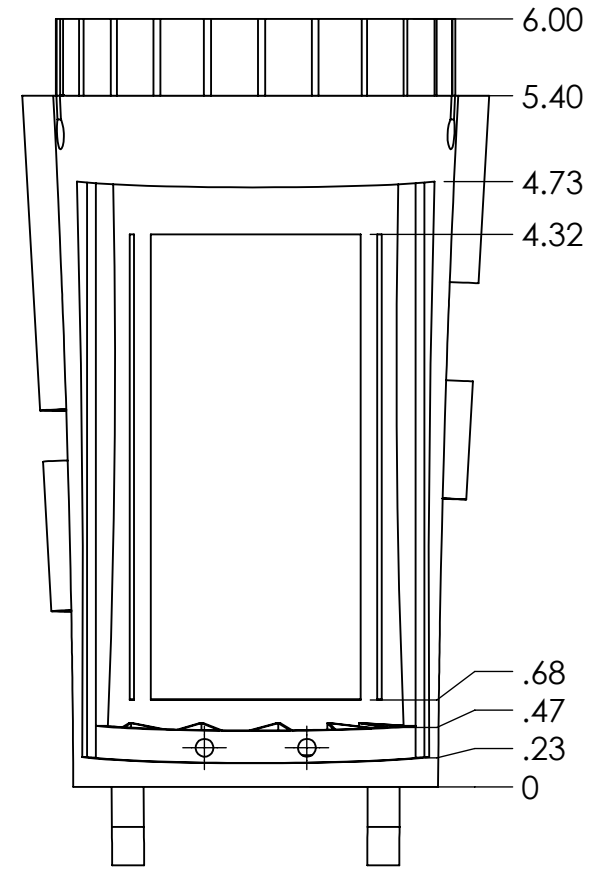

Add own supports:  
Triangles at 0.017" thickness

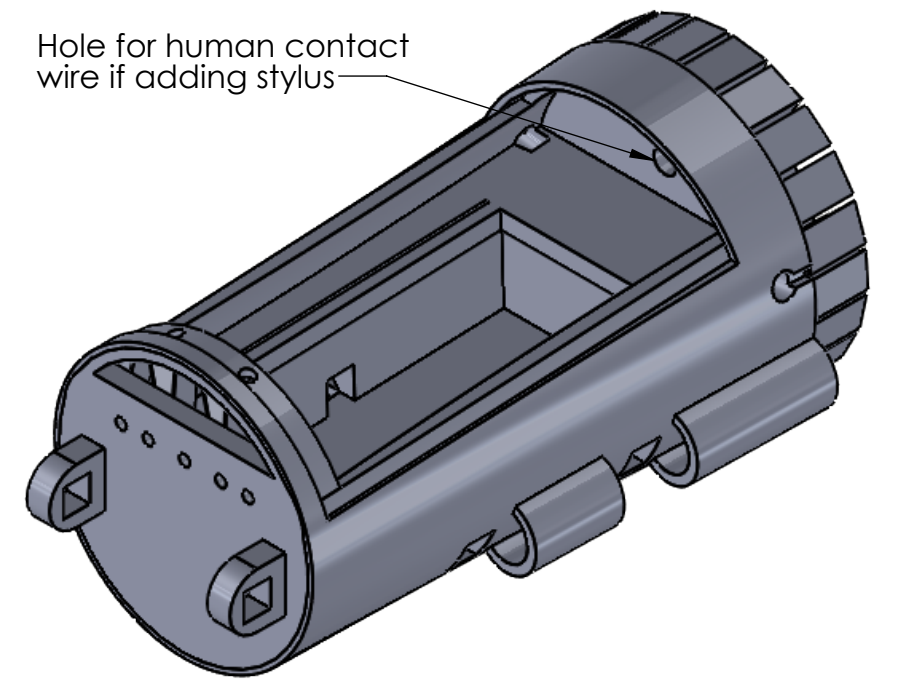
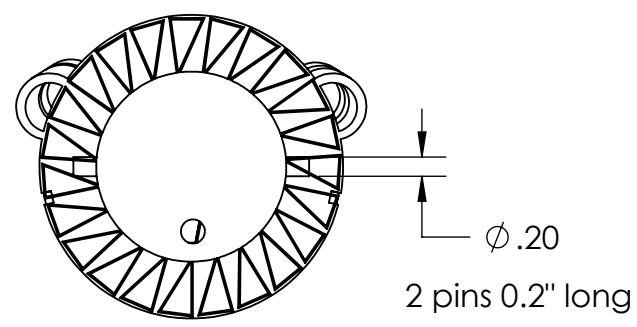

Wire Tubing:  
extruded arc of at least  
0.35" height and 0.5" width

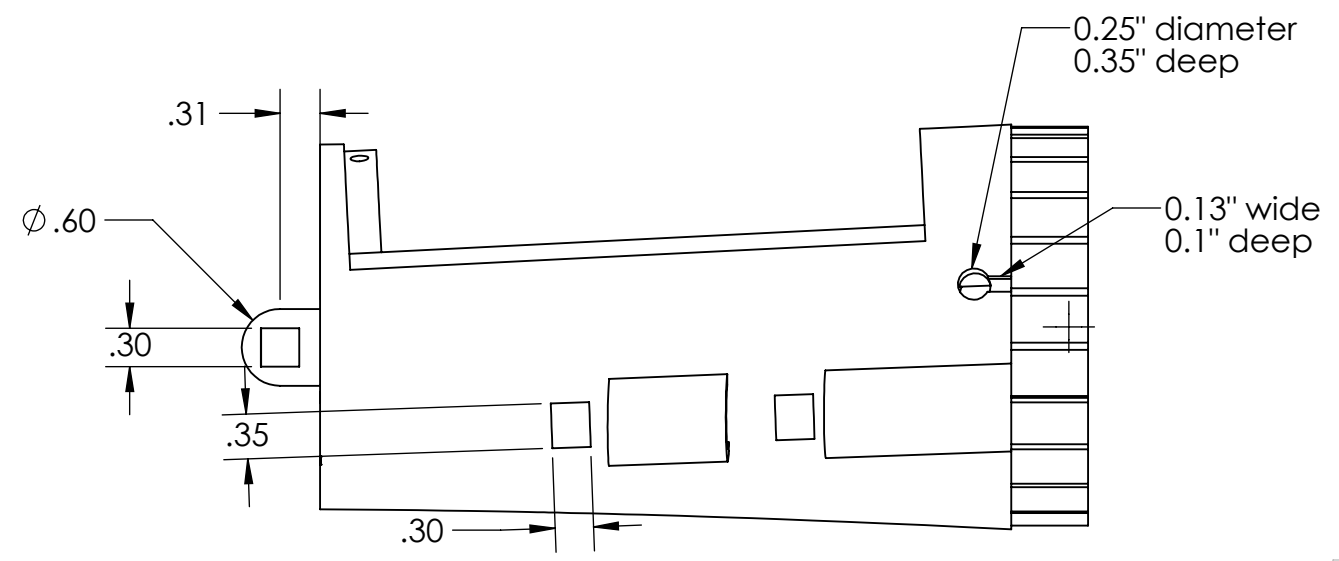
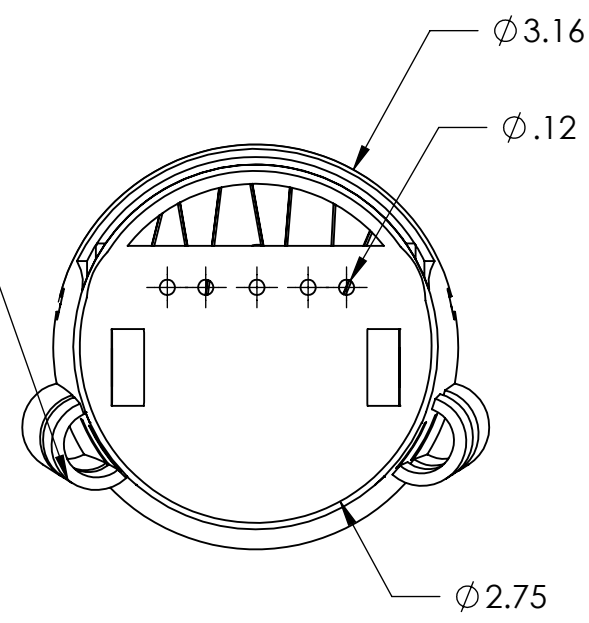

**PROPRIETARY AND CONFIDENTIAL**  
THE INFORMATION CONTAINED IN THIS  
DRAWING IS THE SOLE PROPERTY OF  
<INSERT COMPANY NAME HERE>. ANY  
REPRODUCTION IN PART OR AS A WHOLE  
WITHOUT THE WRITTEN PERMISSION OF  
<INSERT COMPANY NAME HERE> IS  
PROHIBITED.

MATERIAL		
PLA Filament		
TITLE:		
2.5 Front of Arm		
SIZE	DWG. NO.	REV
<b>B</b>		
SCALE: 1:2	WEIGHT:	SHEET 3 OF 7

4

3

2

1

B

B

A

A

4

3

2

1

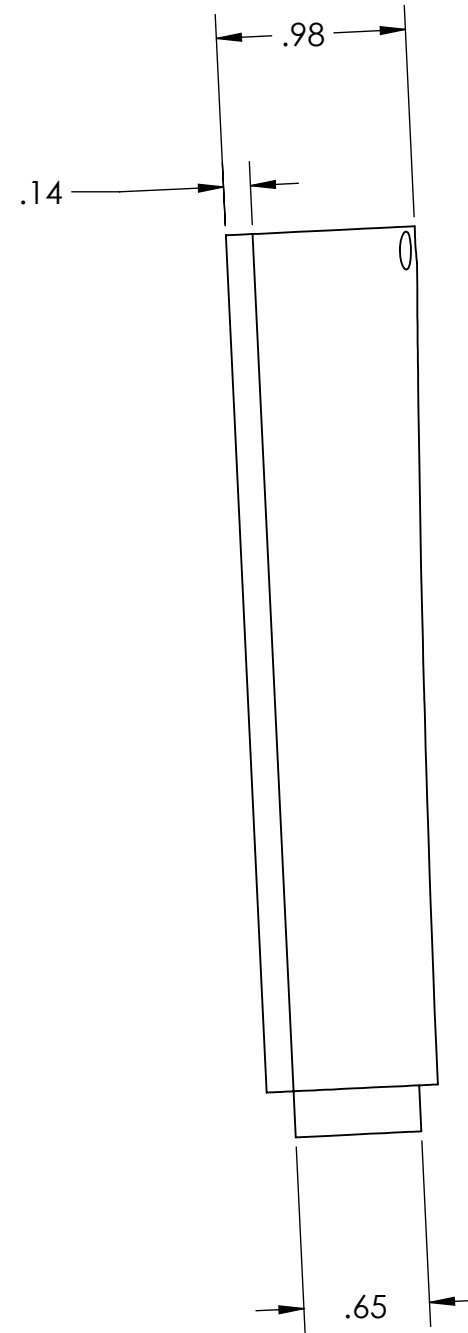
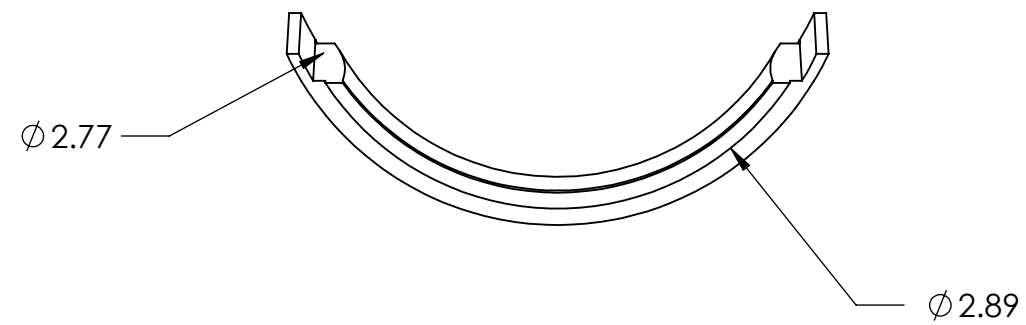
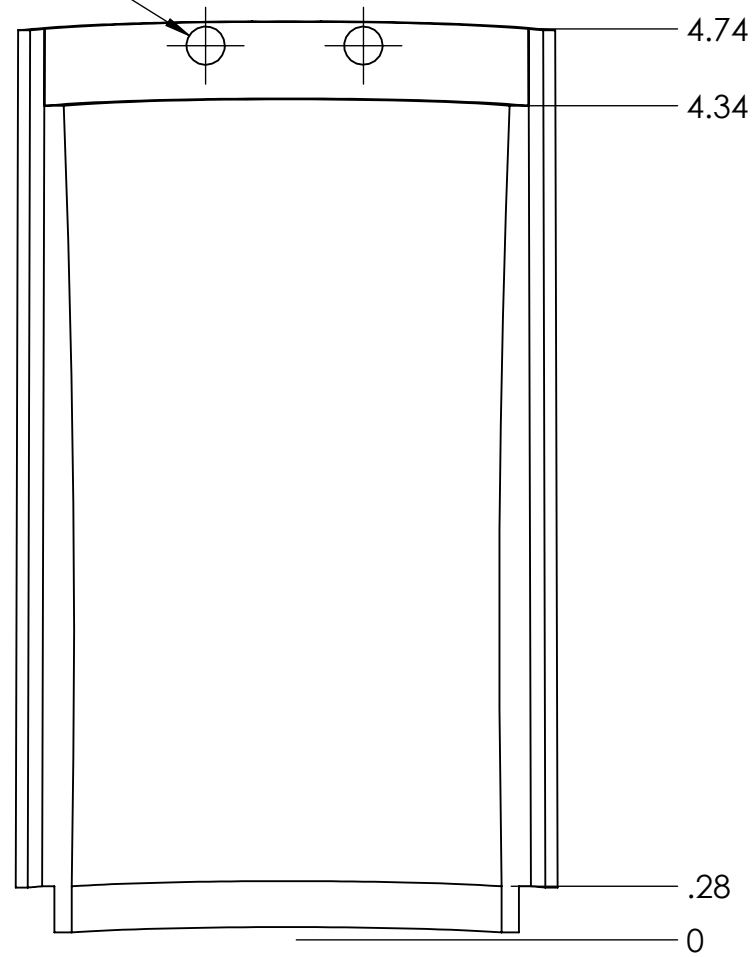
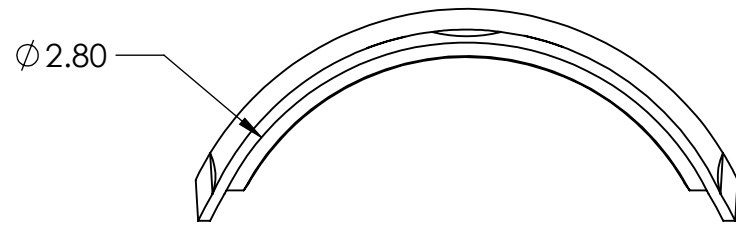

**PROPRIETARY AND CONFIDENTIAL**  
 THE INFORMATION CONTAINED IN THIS DRAWING IS THE SOLE PROPERTY OF <INSERT COMPANY NAME HERE>. ANY REPRODUCTION IN PART OR AS A WHOLE WITHOUT THE WRITTEN PERMISSION OF <INSERT COMPANY NAME HERE> IS PROHIBITED.

MATERIAL		
PLA Filament		
TITLE:		
2.6 Motor Lid		
SIZE	DWG. NO.	REV
<b>B</b>		
SCALE: 1:2	WEIGHT:	SHEET 4 OF 7

4

3

2

1

B

B

A

A



2

1

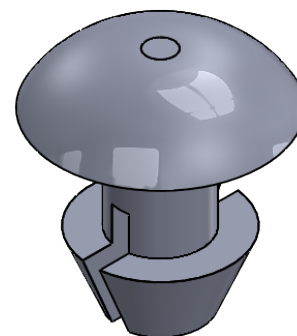
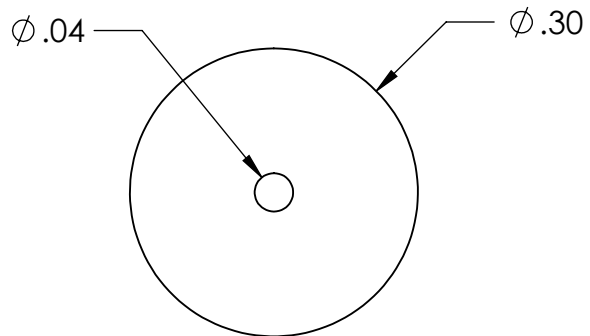

B

B

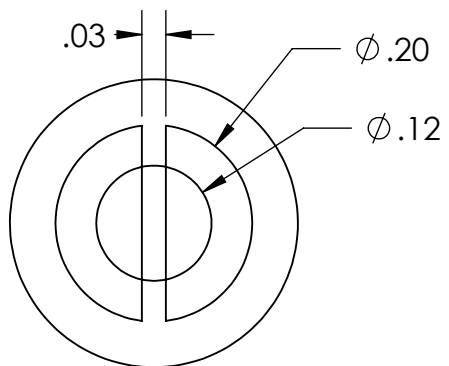
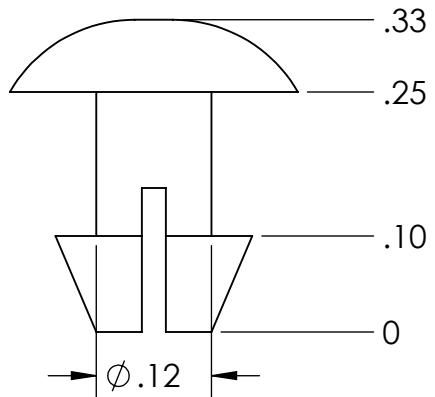

A

A

2

1

**PROPRIETARY AND CONFIDENTIAL**  
 THE INFORMATION CONTAINED IN THIS  
 DRAWING IS THE SOLE PROPERTY OF  
 <INSERT COMPANY NAME HERE>. ANY  
 REPRODUCTION IN PART OR AS A WHOLE  
 WITHOUT THE WRITTEN PERMISSION OF  
 <INSERT COMPANY NAME HERE> IS  
 PROHIBITED.

TITLE:		
<h1>2.7 Lid Pins</h1>		
SIZE	DWG. NO.	REV
<b>A</b>		
SCALE: 5:1	WEIGHT:	SHEET 5 OF 7

4

3

2

1

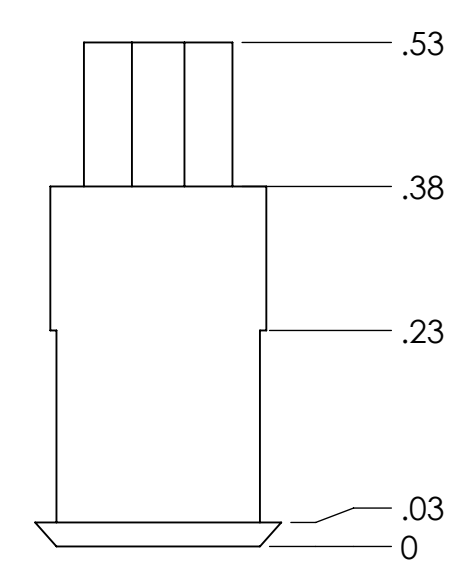
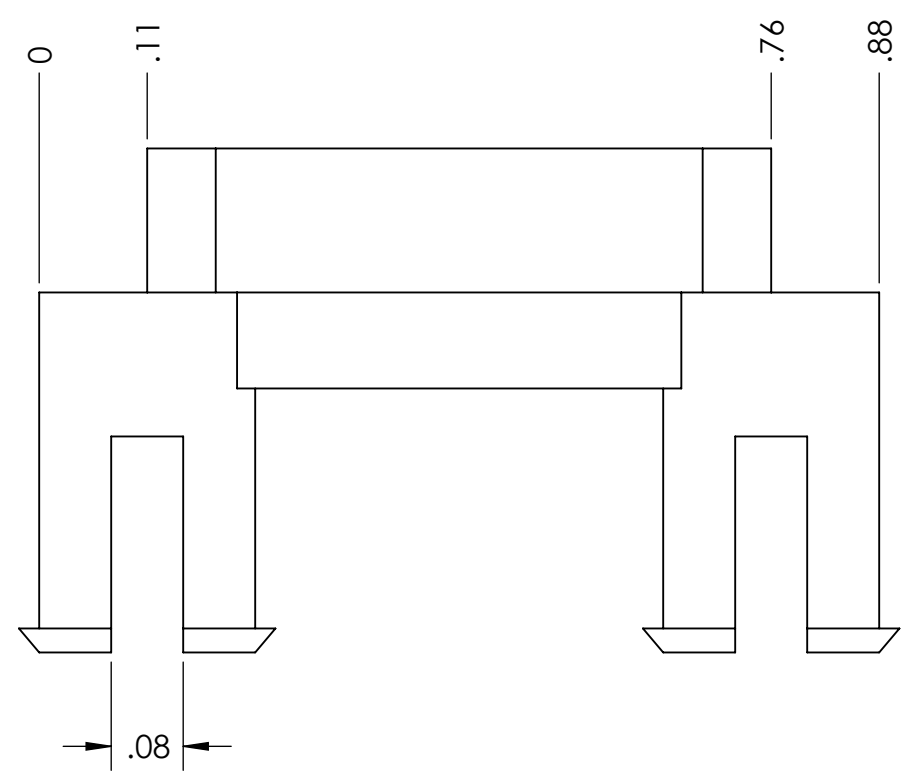
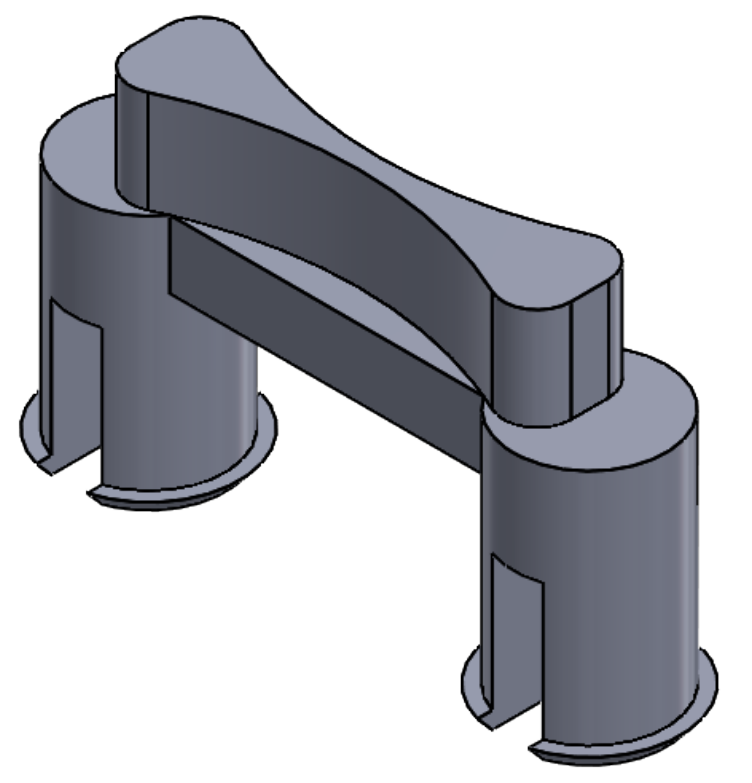
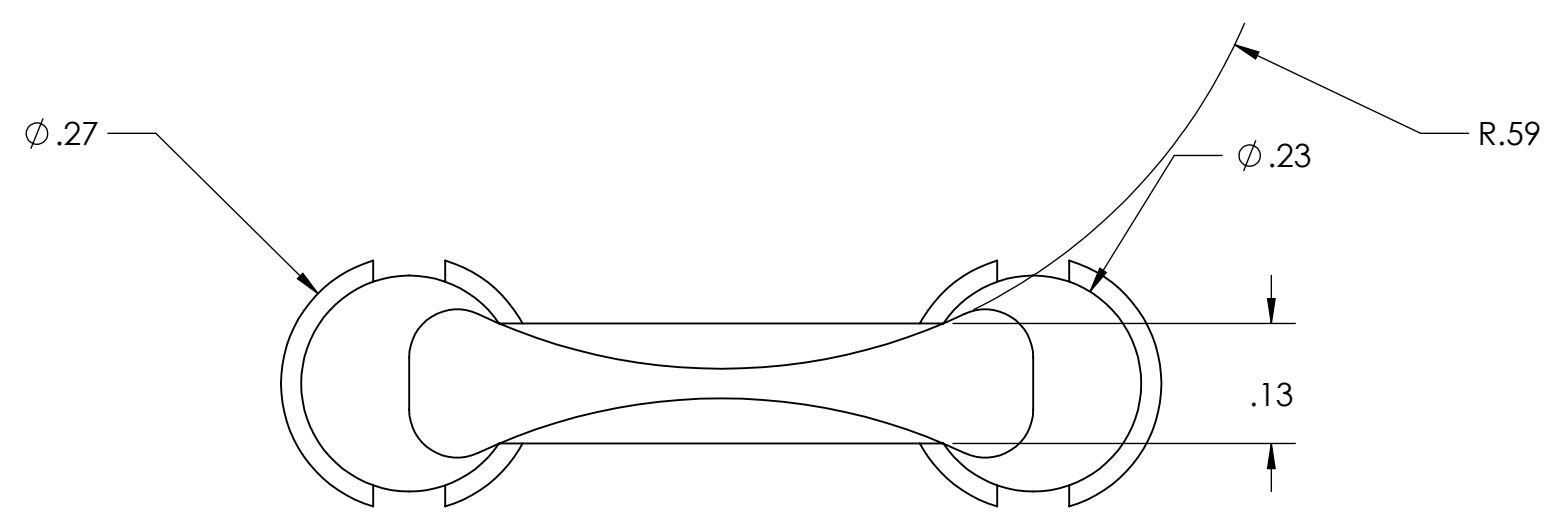

B

B

A

A

4

3

2

1

**PROPRIETARY AND CONFIDENTIAL**  
 THE INFORMATION CONTAINED IN THIS DRAWING IS THE SOLE PROPERTY OF <INSERT COMPANY NAME HERE>. ANY REPRODUCTION IN PART OR AS A WHOLE WITHOUT THE WRITTEN PERMISSION OF <INSERT COMPANY NAME HERE> IS PROHIBITED.

TITLE:		
<b>2.8 Key Attachment</b>		
SIZE	DWG. NO.	REV
<b>B</b>		
SCALE: 5:1	WEIGHT:	SHEET 6 OF 7

2

1

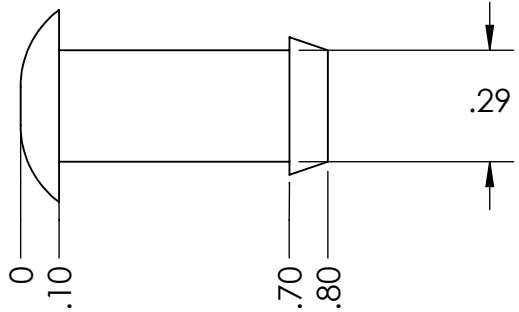
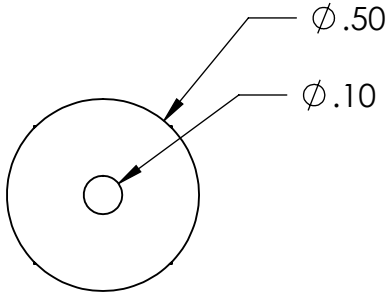
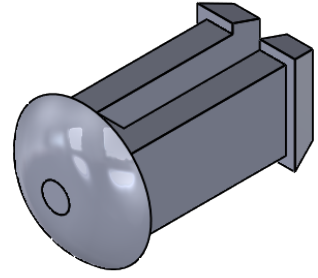
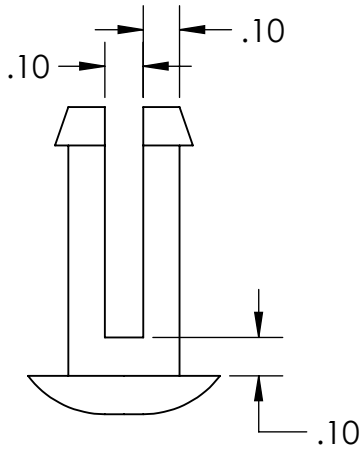

B

B

A

A

2

1

**PROPRIETARY AND CONFIDENTIAL**  
 THE INFORMATION CONTAINED IN THIS  
 DRAWING IS THE SOLE PROPERTY OF  
 <INSERT COMPANY NAME HERE>. ANY  
 REPRODUCTION IN PART OR AS A WHOLE  
 WITHOUT THE WRITTEN PERMISSION OF  
 <INSERT COMPANY NAME HERE> IS  
 PROHIBITED.

TITLE: <b>2.9 Front to Palm Pins</b>		
SIZE <b>A</b>	DWG. NO.	REV
SCALE: 2:1	WEIGHT:	SHEET 7 OF 7

4

3

2

1

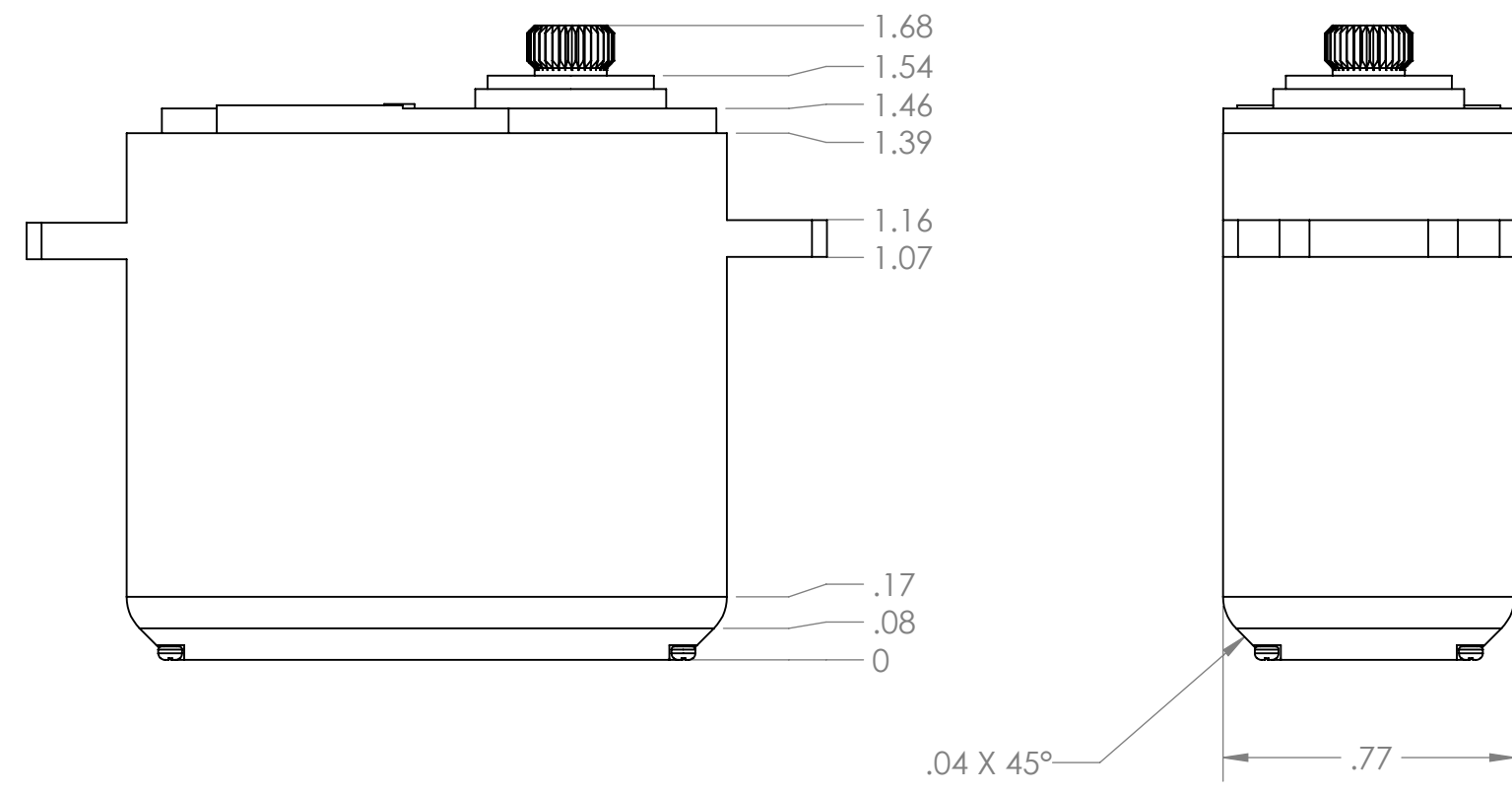
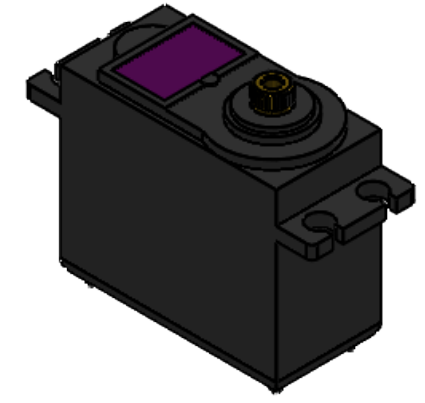
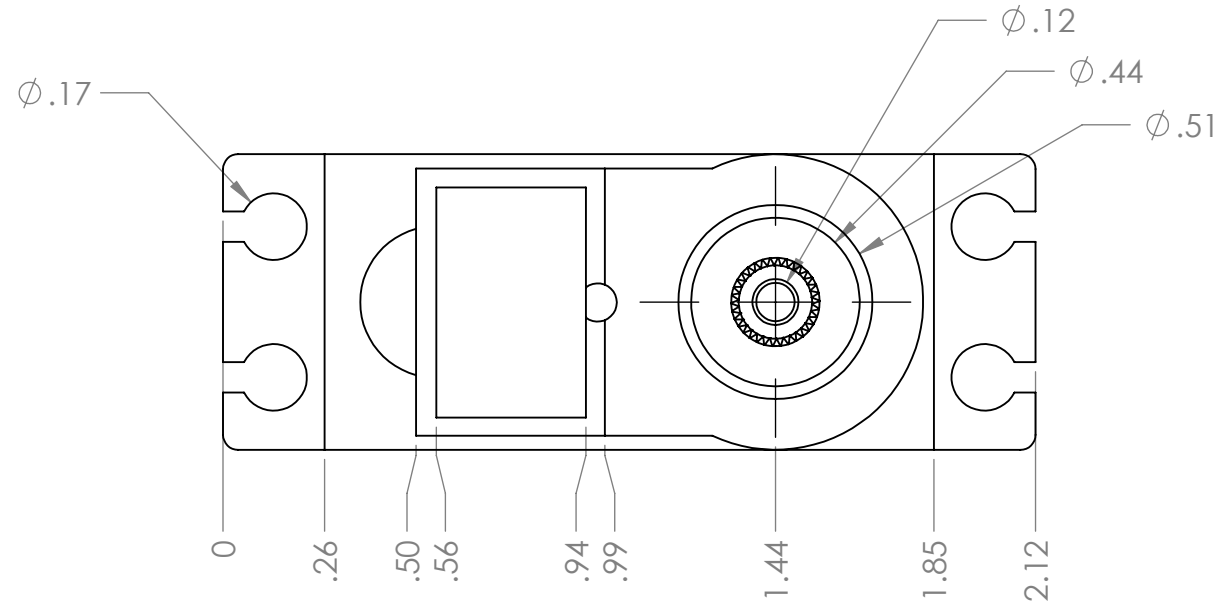

**PROPRIETARY AND CONFIDENTIAL**  
 THE INFORMATION CONTAINED IN THIS DRAWING IS THE SOLE PROPERTY OF <INSERT COMPANY NAME HERE>. ANY REPRODUCTION IN PART OR AS A WHOLE WITHOUT THE WRITTEN PERMISSION OF <INSERT COMPANY NAME HERE> IS PROHIBITED.

TITLE: <b>STANDARD SERVO MOTOR</b>		
SIZE <b>B</b>	DWG. NO.	REV
SCALE: 2:1	WEIGHT:	SHEET 1 OF 1

4

3

2

1

B

B

A

A

4

3

2

1

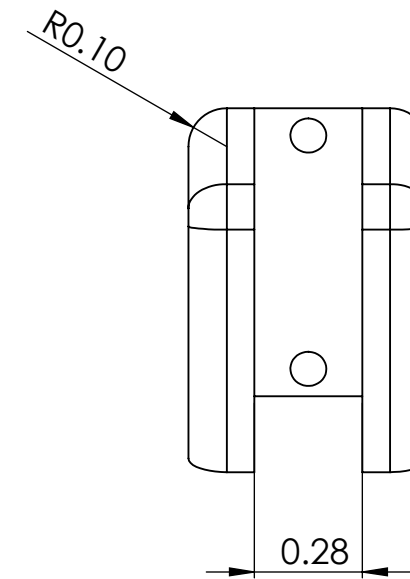
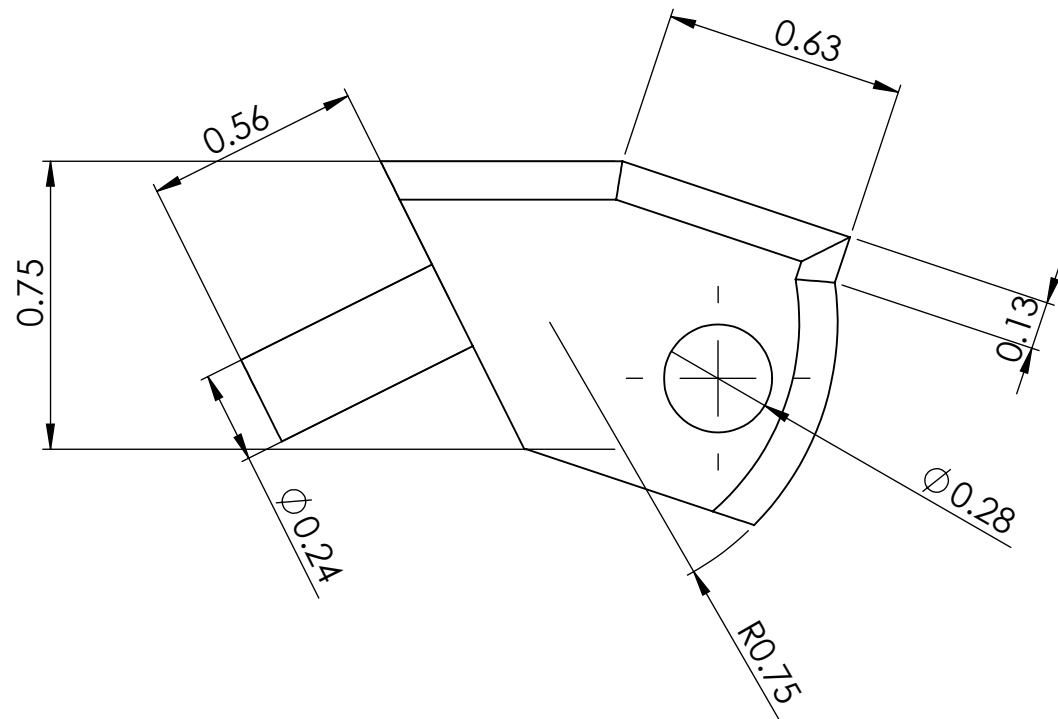
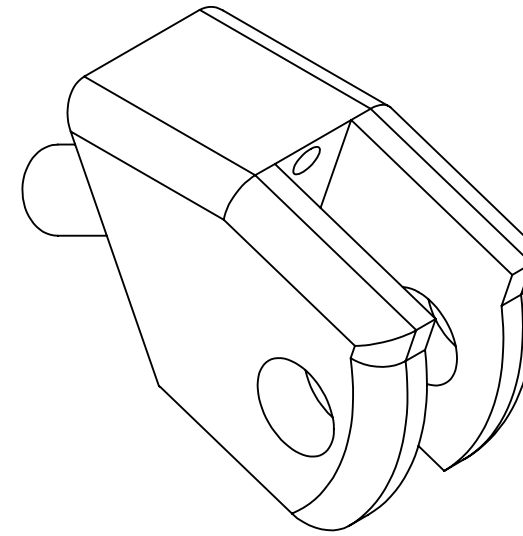
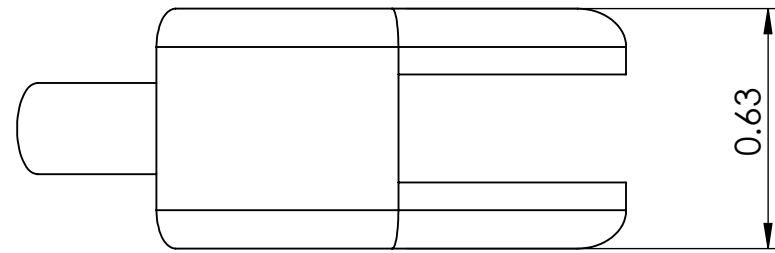

**PROPRIETARY AND CONFIDENTIAL**  
 THE INFORMATION CONTAINED IN THIS DRAWING IS THE SOLE PROPERTY OF <INSERT COMPANY NAME HERE>. ANY REPRODUCTION IN PART OR AS A WHOLE WITHOUT THE WRITTEN PERMISSION OF <INSERT COMPANY NAME HERE> IS PROHIBITED.

		UNLESS OTHERWISE SPECIFIED:	NAME	DATE	TITLE: <b>4.6 Digit 1 Rotating Base</b>
		DIMENSIONS ARE IN INCHES	DRAWN		
		TOLERANCES: FRACTIONAL ± ANGULAR: MACH ± BEND ± TWO PLACE DECIMAL ± THREE PLACE DECIMAL ±	CHECKED		
		INTERPRET GEOMETRIC TOLERANCING PER:	ENG APPR.		
		MATERIAL	MFG APPR.		SIZE DWG. NO. REV
NEXT ASSY	USED ON	FINISH	COMMENTS:		Base_B_Digit 1 040142019
APPLICATION		DO NOT SCALE DRAWING			SCALE: 2:1 WEIGHT: SHEET 1 OF 1

4

3

2

1

B

B

A

A

4

3

2

1

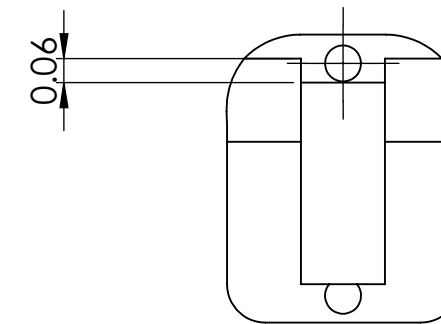
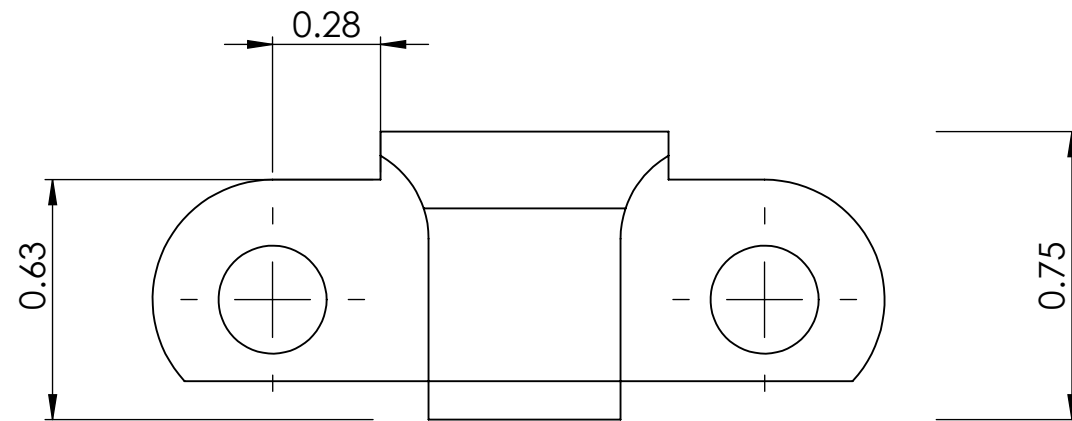
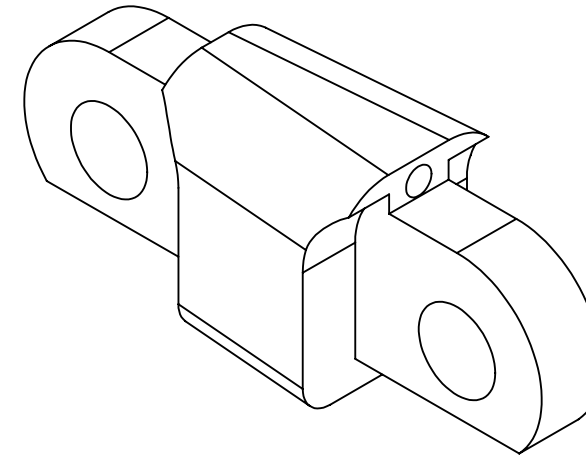
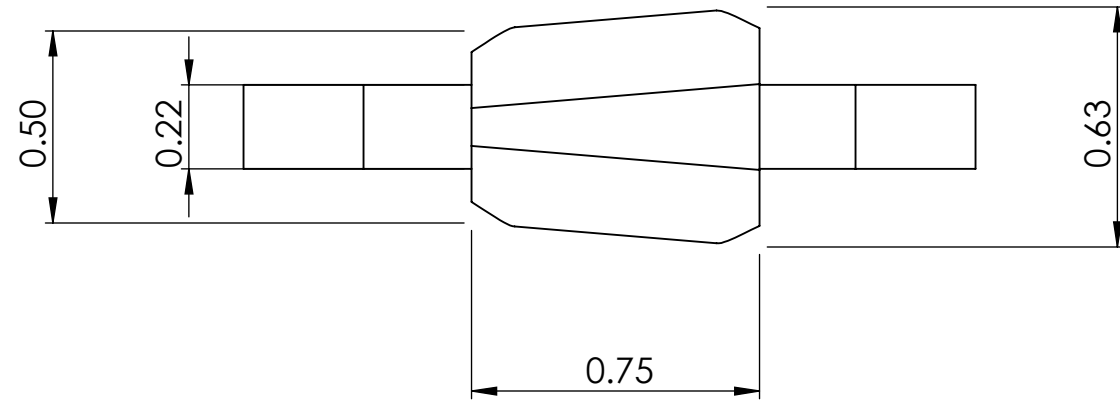

**PROPRIETARY AND CONFIDENTIAL**  
 THE INFORMATION CONTAINED IN THIS DRAWING IS THE SOLE PROPERTY OF <INSERT COMPANY NAME HERE>. ANY REPRODUCTION IN PART OR AS A WHOLE WITHOUT THE WRITTEN PERMISSION OF <INSERT COMPANY NAME HERE> IS PROHIBITED.

		UNLESS OTHERWISE SPECIFIED:		NAME	DATE
		DIMENSIONS ARE IN INCHES	DRAWN		
		TOLERANCES:	CHECKED		
		FRACTIONAL ±	ENG APPR.		
		ANGULAR: MACH ± BEND ±	MFG APPR.		
		TWO PLACE DECIMAL ±	Q.A.		
		THREE PLACE DECIMAL ±	COMMENTS:		
		INTERPRET GEOMETRIC TOLERANCING PER:			
		MATERIAL			
		FINISH			
NEXT ASSY	USED ON				
APPLICATION		DO NOT SCALE DRAWING			

TITLE:  
 4.7, 4.9, 4.11,  
 4.13, 4.15

Proximal\_Digit\_1\_04282019

SCALE: 2:1 WEIGHT: SHEET 1 OF 1

4

3

2

1

4

3

2

1

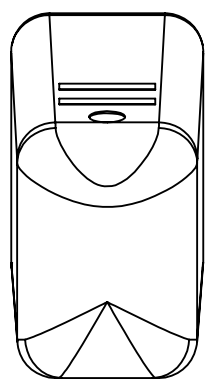
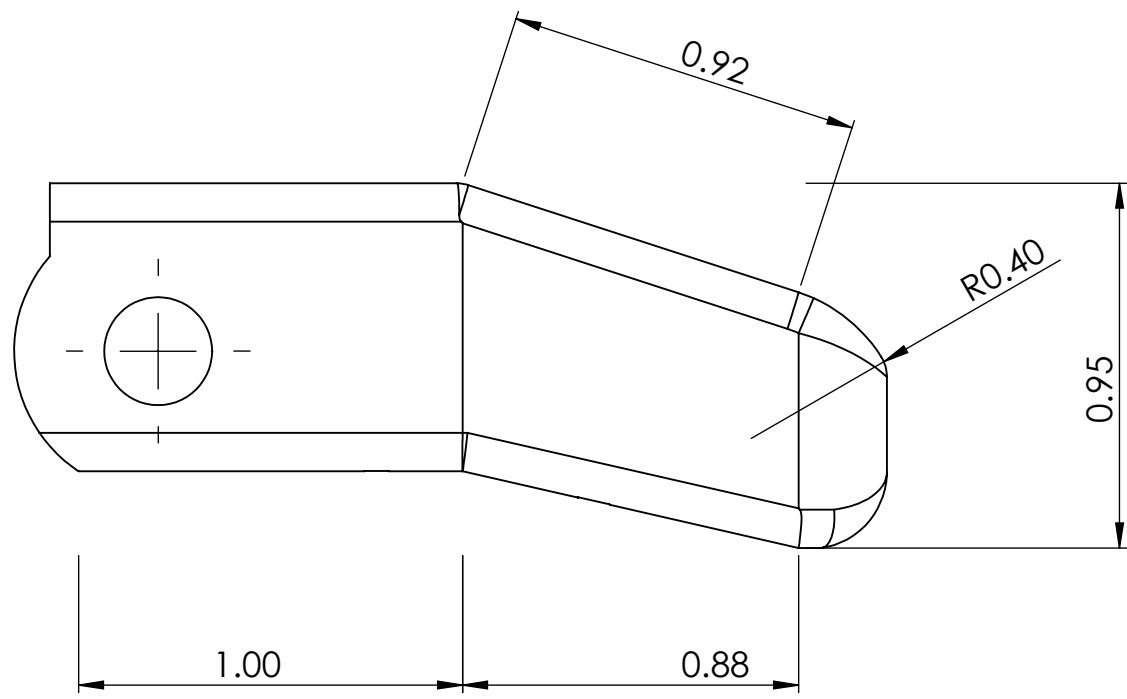
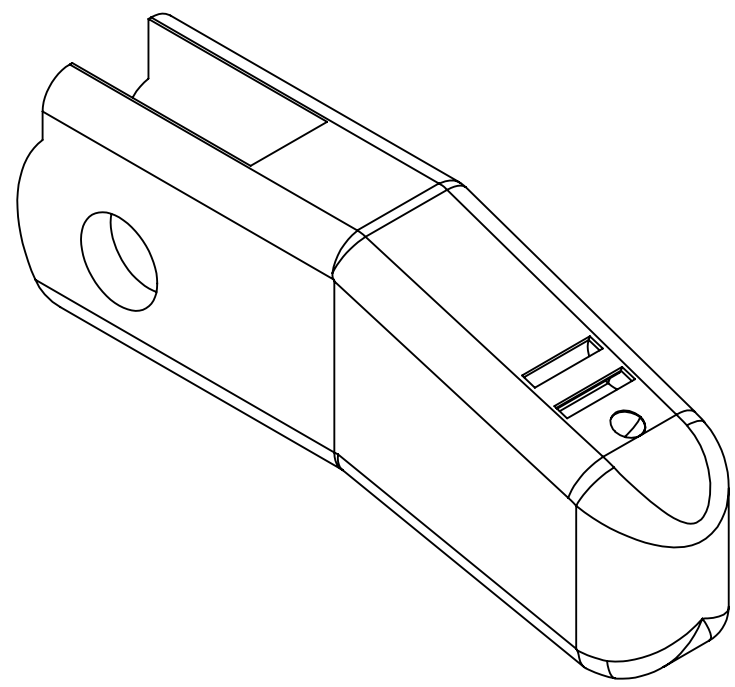
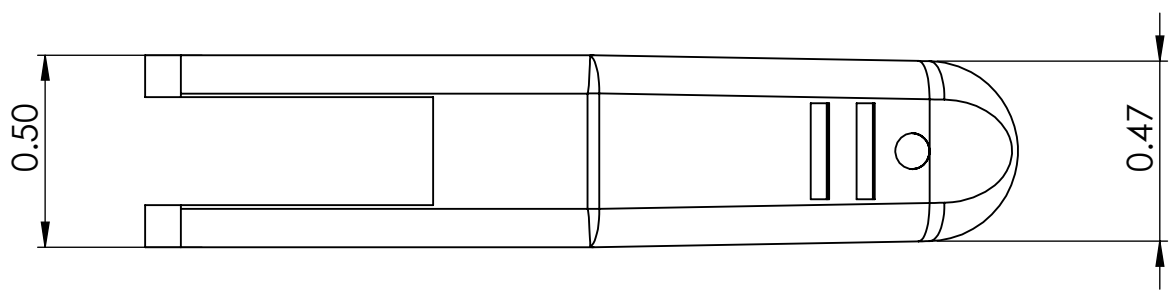

**PROPRIETARY AND CONFIDENTIAL**  
 THE INFORMATION CONTAINED IN THIS DRAWING IS THE SOLE PROPERTY OF <INSERT COMPANY NAME HERE>. ANY REPRODUCTION IN PART OR AS A WHOLE WITHOUT THE WRITTEN PERMISSION OF <INSERT COMPANY NAME HERE> IS PROHIBITED.

		UNLESS OTHERWISE SPECIFIED:	NAME	DATE	TITLE: <b>4.8, 4.10, 4.12, 4.14, 4.16 Distal Digits 1-5</b>	
		DIMENSIONS ARE IN INCHES TOLERANCES: FRACTIONAL ± ANGULAR: MACH ± BEND ± TWO PLACE DECIMAL ± THREE PLACE DECIMAL ±	DRAWN			SIZE DWG. NO. REV
		INTERPRET GEOMETRIC TOLERANCING PER:	CHECKED			Distal_Digit 2 04142019
		MATERIAL	ENG APPR.			
NEXT ASSY	USED ON	FINISH	MFG APPR.		SCALE: 2:1 WEIGHT: SHEET 1 OF 1	
APPLICATION		DO NOT SCALE DRAWING	Q.A.			
			COMMENTS:			

4

3

2

1

B

B

A

A

4

3

2

1

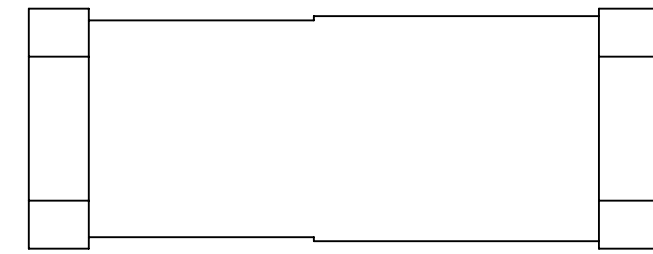
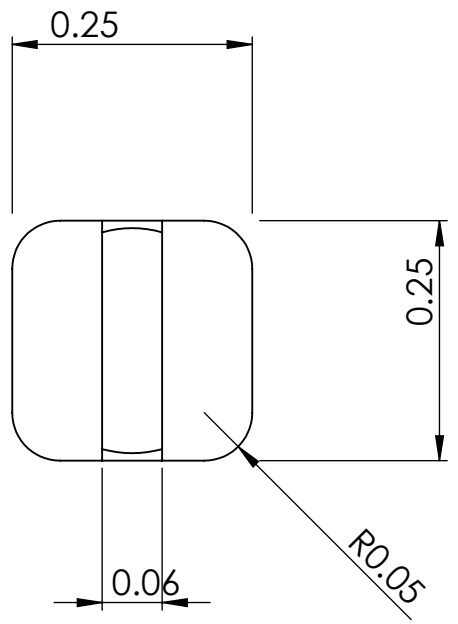
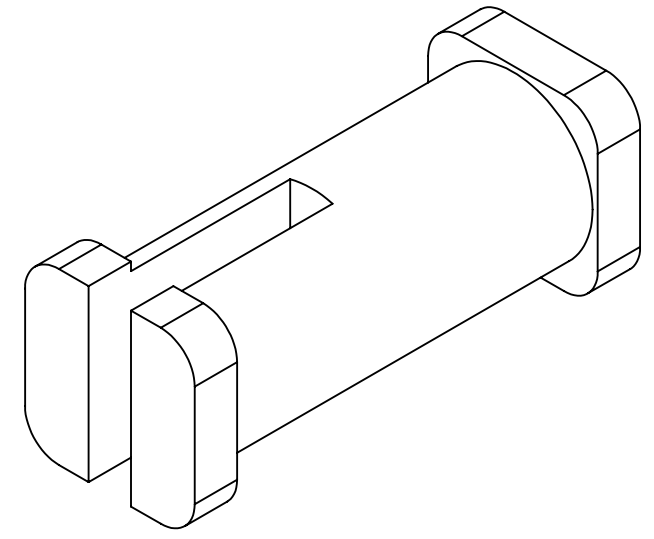
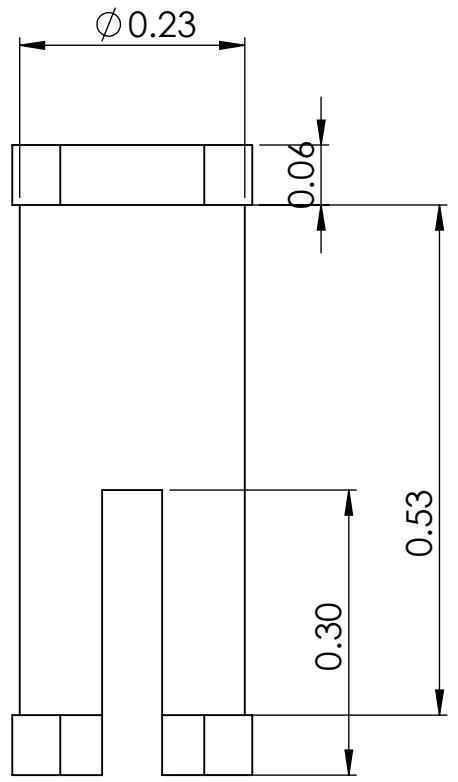

B

B

A

A

**PROPRIETARY AND CONFIDENTIAL**  
 THE INFORMATION CONTAINED IN THIS DRAWING IS THE SOLE PROPERTY OF <INSERT COMPANY NAME HERE>. ANY REPRODUCTION IN PART OR AS A WHOLE WITHOUT THE WRITTEN PERMISSION OF <INSERT COMPANY NAME HERE> IS PROHIBITED.

		UNLESS OTHERWISE SPECIFIED:	NAME	DATE
		DIMENSIONS ARE IN INCHES	DRAWN	
		TOLERANCES:	CHECKED	
		FRACTIONAL ±	ENG APPR.	
		ANGULAR: MACH ± BEND ±	MFG APPR.	
		TWO PLACE DECIMAL ±	Q.A.	
		THREE PLACE DECIMAL ±	COMMENTS:	
		INTERPRET GEOMETRIC TOLERANCING PER:	TITLE: <b>4.4 Finger Hinge Pin</b> SIZE DWG. NO. REV <b>Digit B Hinge Pin 04114019</b>	
NEXT ASSY	USED ON	MATERIAL		
APPLICATION		FINISH		
		DO NOT SCALE DRAWING	SCALE: 5:1	WEIGHT:
			SHEET 1 OF 1	

4

3

2

1



4

3

2

1

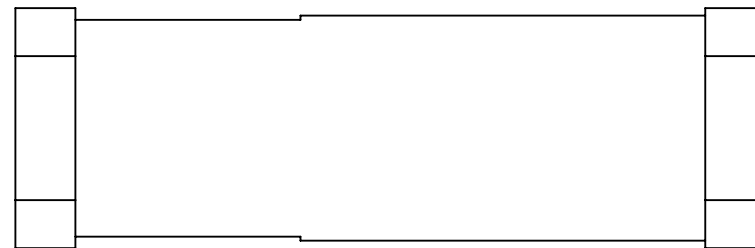
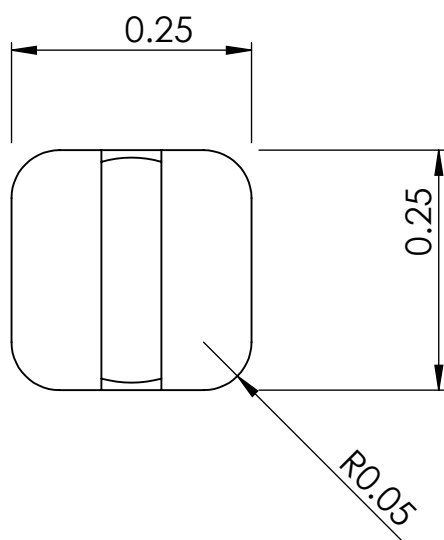
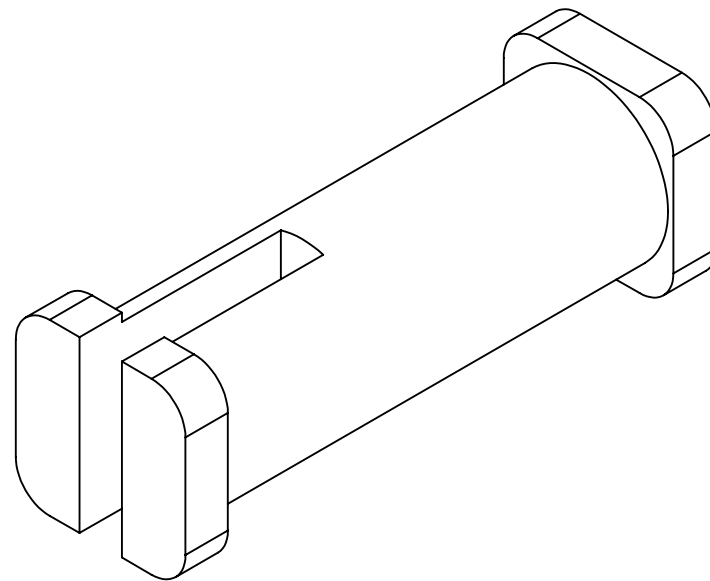
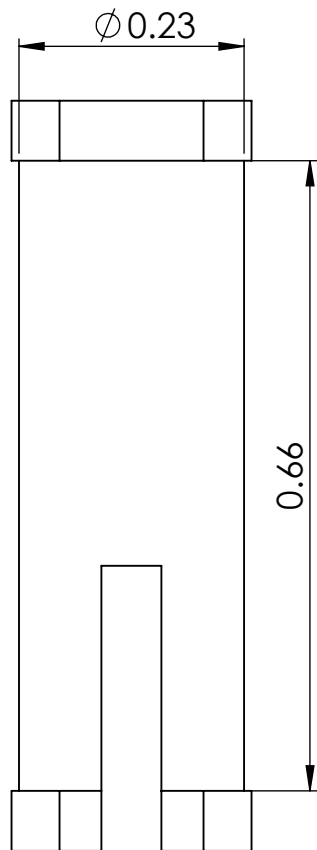

B

B

A

A

**PROPRIETARY AND CONFIDENTIAL**  
 THE INFORMATION CONTAINED IN THIS DRAWING IS THE SOLE PROPERTY OF <INSERT COMPANY NAME HERE>. ANY REPRODUCTION IN PART OR AS A WHOLE WITHOUT THE WRITTEN PERMISSION OF <INSERT COMPANY NAME HERE> IS PROHIBITED.

		UNLESS OTHERWISE SPECIFIED:	NAME	DATE
		DIMENSIONS ARE IN INCHES	DRAWN	
		TOLERANCES:	CHECKED	
		FRACTIONAL $\pm$	ENG APPR.	
		ANGULAR: MACH $\pm$ BEND $\pm$	MFG APPR.	
		TWO PLACE DECIMAL $\pm$	Q.A.	
		THREE PLACE DECIMAL $\pm$	COMMENTS:	
		INTERPRET GEOMETRIC TOLERANCING PER:	<b>Digit Hinge Bin Rotating Base</b> TITLE: <b>4.5 Rotating Base Hinge Pin</b> SIZE DWG. NO. REV SCALE: 5:1 WEIGHT: SHEET 1 OF 1	
		MATERIAL		
		FINISH		
NEXT ASSY	USED ON	APPLICATION	DO NOT SCALE DRAWING	

4

3

2

1

04

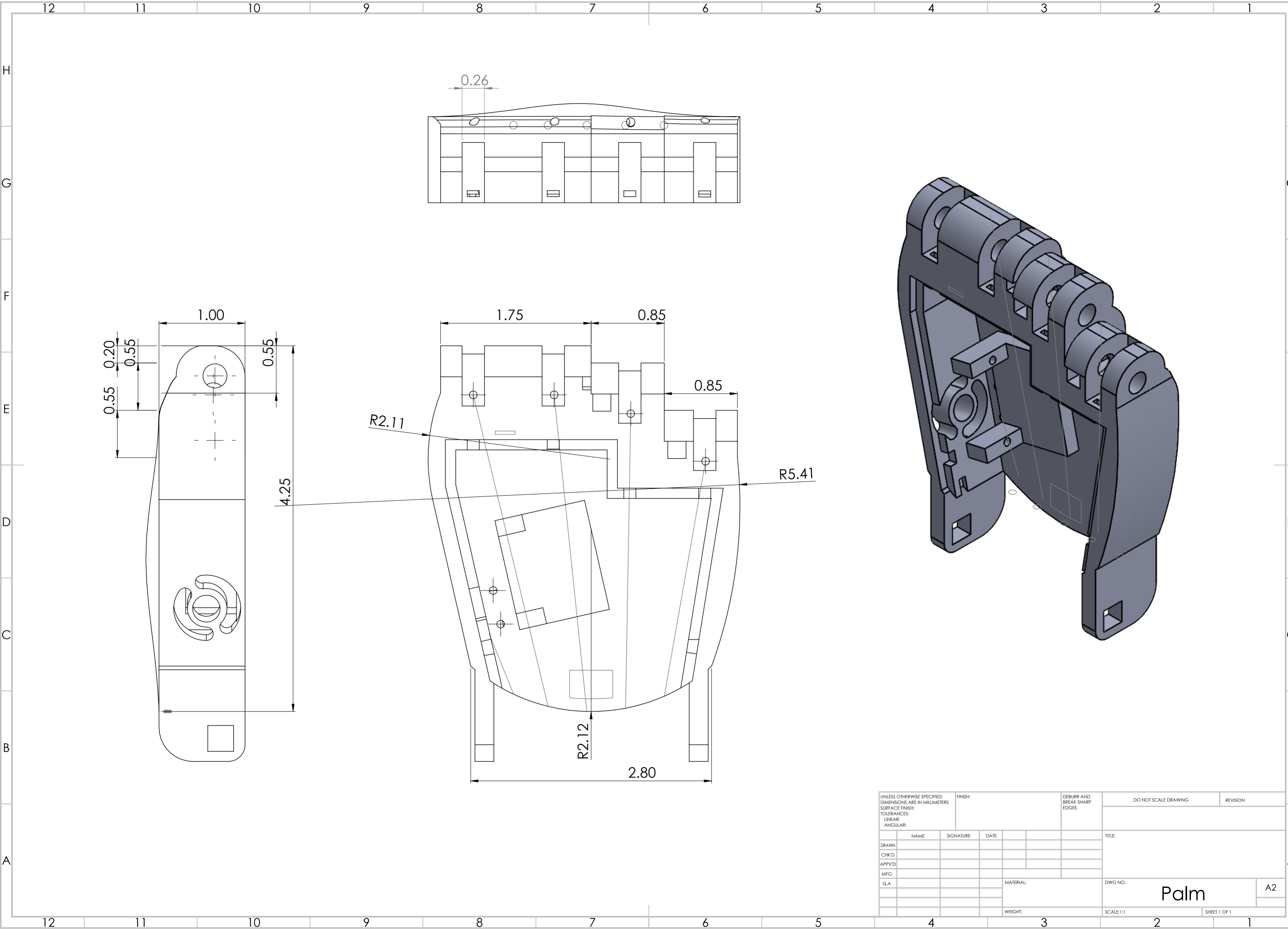

UNLESS OTHERWISE SPECIFIED: DIMENSIONS ARE IN MILLIMETERS				FINISH:		DEBURR AND BREAK SHARP EDGES		DO NOT SCALE DRAWING		REVISION	
SURFACE FINISH:											
TOLERANCES:											
LINEAR:											
ANGULAR:											
		NAME	SIGNATURE	DATE				TITLE:			
DRAWN											
CHK'D											
APP'VD											
MFG											
Q.A											
				MATERIAL:				DWG. NO.		A2	
				WEIGHT:				SCALE:1:1		SHEET 1 OF 1	
								Palm			

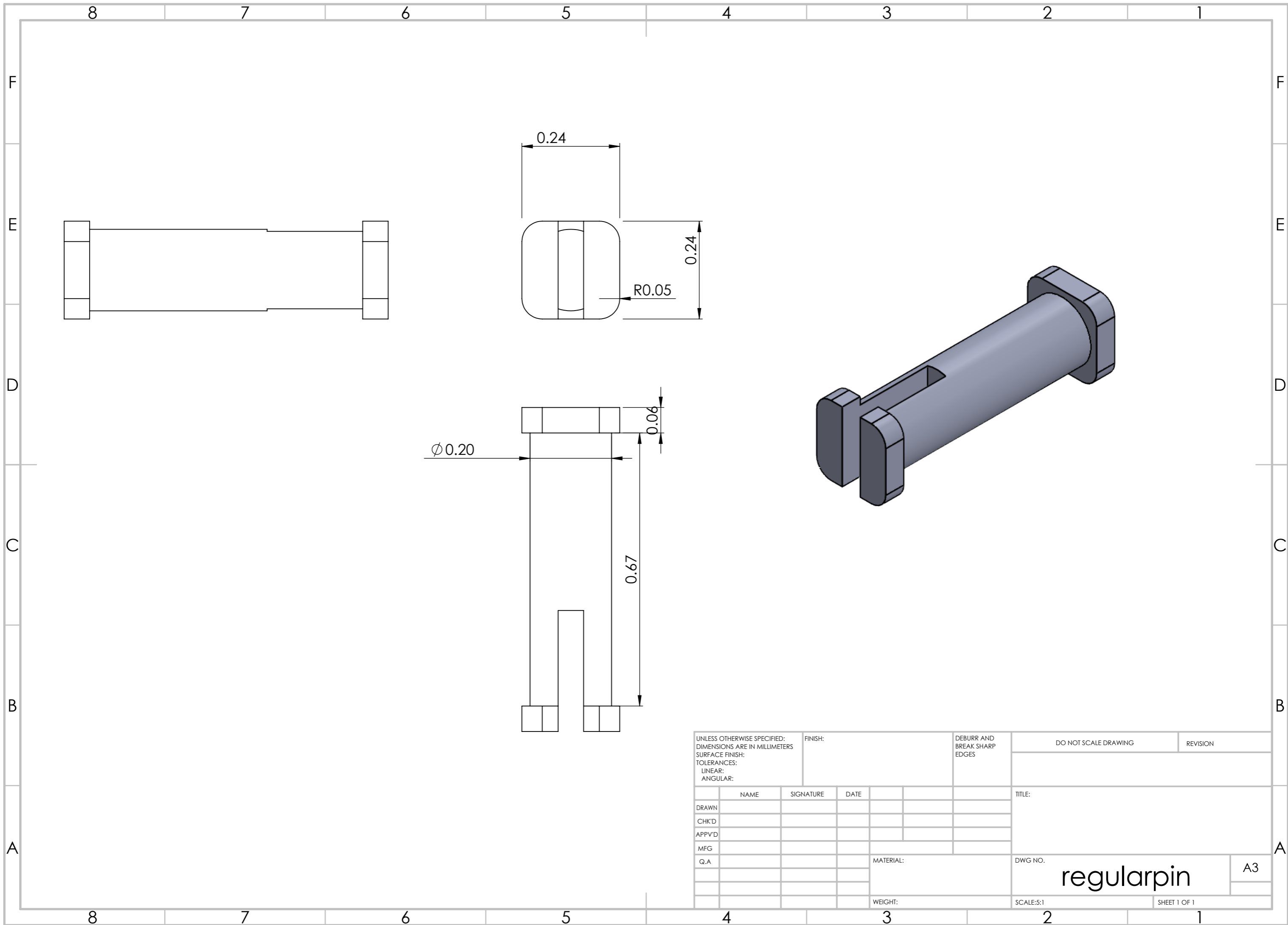

UNLESS OTHERWISE SPECIFIED: DIMENSIONS ARE IN MILLIMETERS SURFACE FINISH: TOLERANCES: LINEAR: ANGULAR:			FINISH:		DEBURR AND BREAK SHARP EDGES		DO NOT SCALE DRAWING		REVISION		
DRAWN			NAME		SIGNATURE		DATE		TITLE:		
CHK'D											
APPV'D											
MFG											
Q.A							MATERIAL:		DWG NO.		
									regularpin		
							WEIGHT:		SCALE:5:1		
									SHEET 1 OF 1		
									A3		

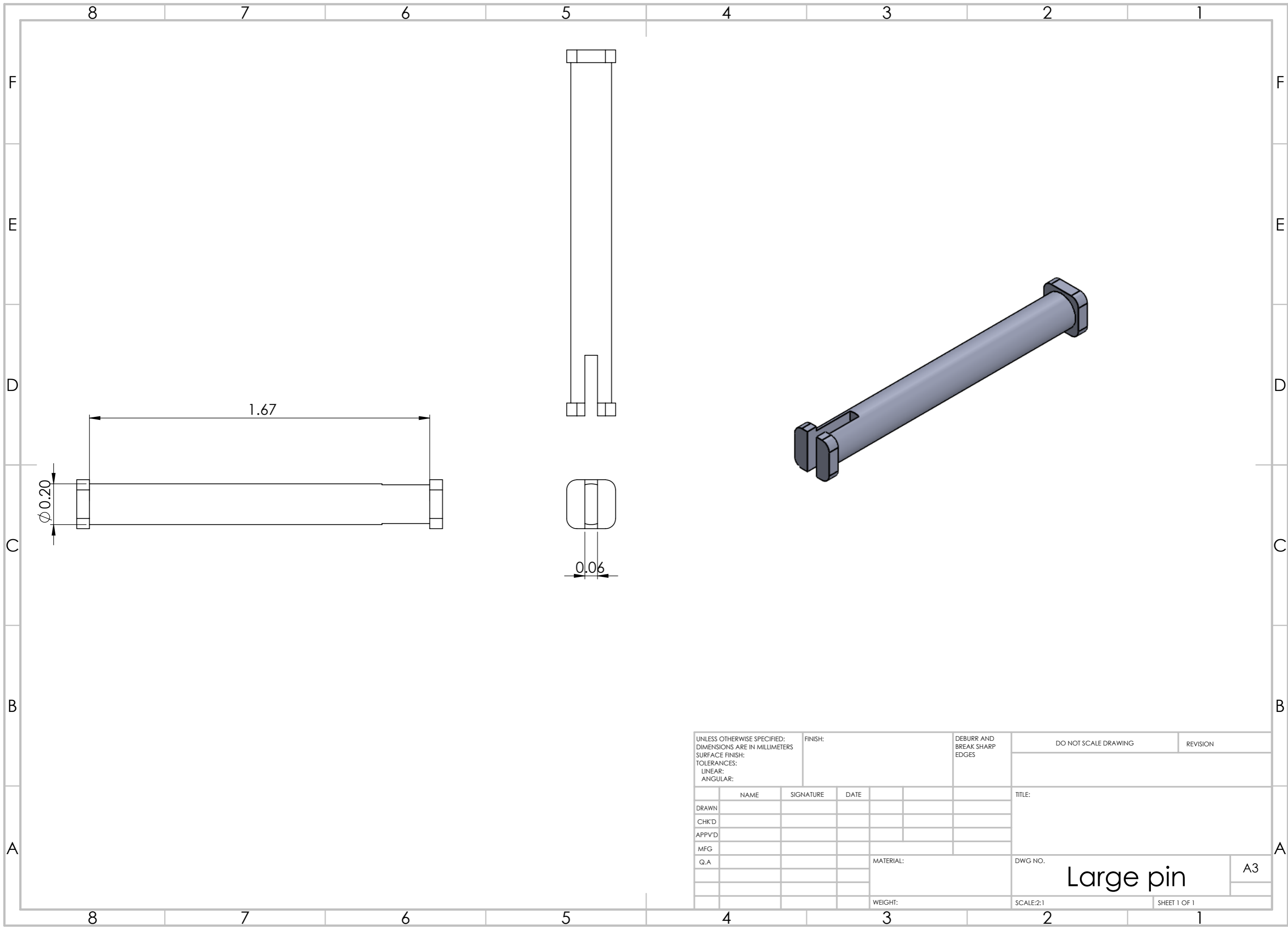

UNLESS OTHERWISE SPECIFIED: DIMENSIONS ARE IN MILLIMETERS SURFACE FINISH: TOLERANCES: LINEAR: ANGULAR:			FINISH:		DEBURR AND BREAK SHARP EDGES		DO NOT SCALE DRAWING		REVISION		
DRAWN			NAME		SIGNATURE		DATE		TITLE:		
CHK'D											
APPV'D											
MFG											
Q.A							MATERIAL:		DWG NO.		
									Large pin		
							WEIGHT:		SCALE:2:1		
									SHEET 1 OF 1		
									A3		

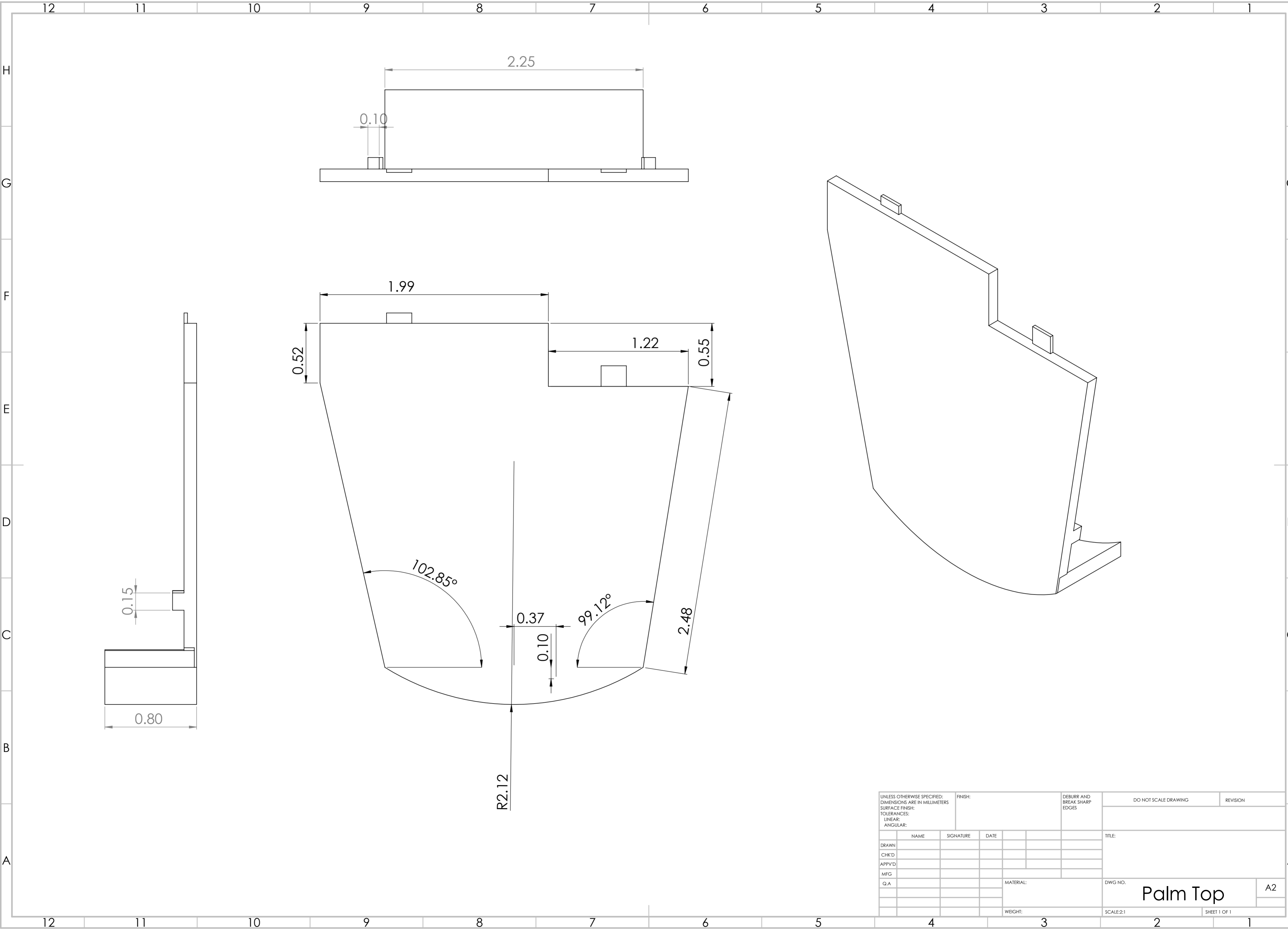

UNLESS OTHERWISE SPECIFIED: DIMENSIONS ARE IN MILLIMETERS				FINISH:		DEBURR AND BREAK SHARP EDGES		DO NOT SCALE DRAWING		REVISION	
TOLERANCES: LINEAR: ANGULAR:											
DRAWN				NAME		SIGNATURE		DATE		TITLE:	
CHK'D											
APPV'D											
MFG											
Q.A								MATERIAL:		DWG NO.	
										Palm Top	
								WEIGHT:		SCALE:2:1	
										SHEET 1 OF 1	
										A2	